



the Mist

ANDROMEDA

ANDROMEDA

the Mist

for individual contemplation only

Space within the earth's atmosphere is a limited extent, a period of time, a measurable distance.
Contemplate the void that surrounds objects and answer me: how many perceptions, emotions,
experiences cross us being them part of such space?

Wonder now about new perspectives. Evoke a mood. Emphasize an atmosphere.
You see? It's always a matter of being the most delicate and passionate before being superimposing.

This is what "The Mist" is all about. The expression of our human experience within the world.
Beautifying, improving, universalizing a fictional world, a world of illusion, appearances, aesthetics
and images is as strenuous as inventing new affinities.

Re-interpreting existing worlds implies the use of mature senses well beyond reference to reality.

Marzia Vianello
Andromeda International

the Mist

da contemplare in solitario

Lo spazio nell'atmosfera terrestre è una dimensione limitata, è un periodo di tempo, una distanza misurabile.

Contemplate il vuoto che circonda gli oggetti e ditemi: quante percezioni, emozioni, esperienze che sono parte di quello spazio ci attraversano?

Interrogatevi ora su nuove prospettive. Evocate uno stato d'animo. Enfatizzate un'atmosfera.

Vedete? È sempre questione di usare la massima delicatezza e passione prima di imporsi.

Questo è "The Mist": l'espressione della nostra esperienza umana entro i confini del mondo.

Abbellire, migliorare e rendere universale un mondo fittizio, un mondo di illusioni, di esteriorità, di apparenza e di immagini è arduo quanto inventare nuove affinità: reinterpretare dei mondi esistenti richiede l'uso di sensi maturi, ben oltre qualsiasi riferimento alla realtà.



Black

pag. 6



White

pag. 22



Red

pag. 32



Clear

pag. 54



Pearly

pag. 74

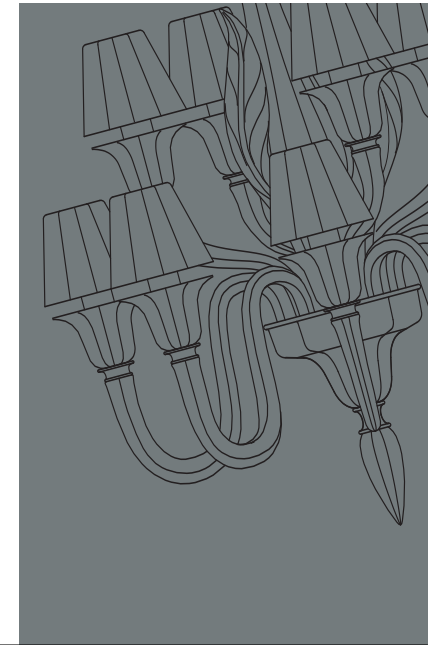

Technical session

pag. 94

designer leo de carlo

Black





1/6601/85/2/8+4

1/6601/85/2/8



10
Black



1/6601/85/2/5



3/6601/85/2/3



14

Black

3/6604/85/2/1





17
Black

3/6606/85/2/1





designer **leo de carlo**

White







26

White

3/6605/107/2/2





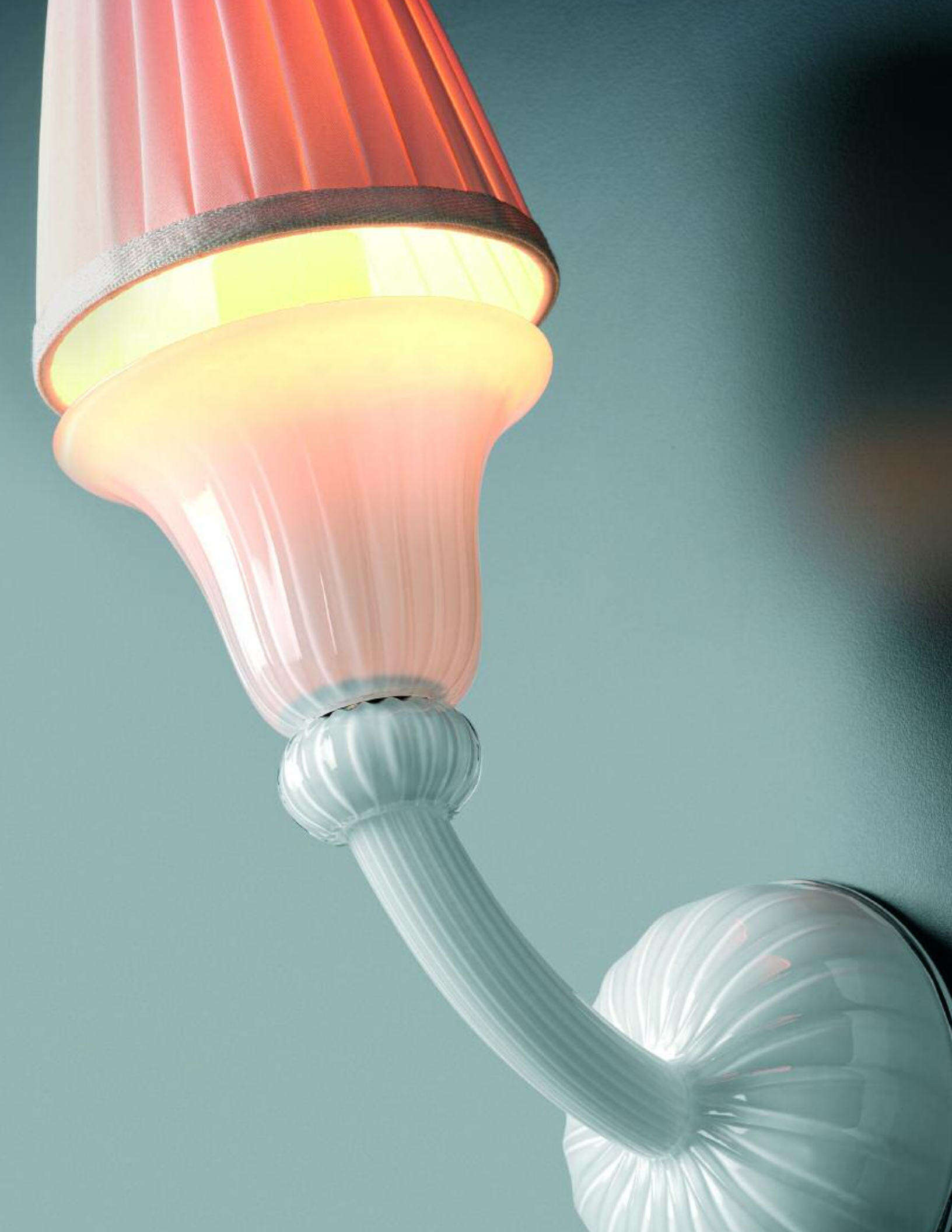

designer **leo de carlo**

Red





1/6601/83/2/8+4





1/6601/83/2/8



1/6601/83/2/8





40

Red

3/6601/83/2/3





43

Red

6/6608/83/2/3A



44

Red



6/6608/83/2/3B





5/6601/83/2/1



50

Red

3/6605/83/2/2





52

Red

3/6604/83/2/1



designer **leo de carlo**

Clear





1/6601/01/2/8+4









62

Clear

3/6601/01/2/3





64

Clear



3/6605/01/2/2







68

Clear

6/6609/01/2/3A





71

Clear

6/6609/01/2/3B



72

Clear

5/6601/01/2/1



designer **leo de carlo**

Pearly









80

Pearly

3/6601/106/2/3





3/6606/106/2/1

the Mist





the Artist





the artist



designer leo de carlo

Technical session

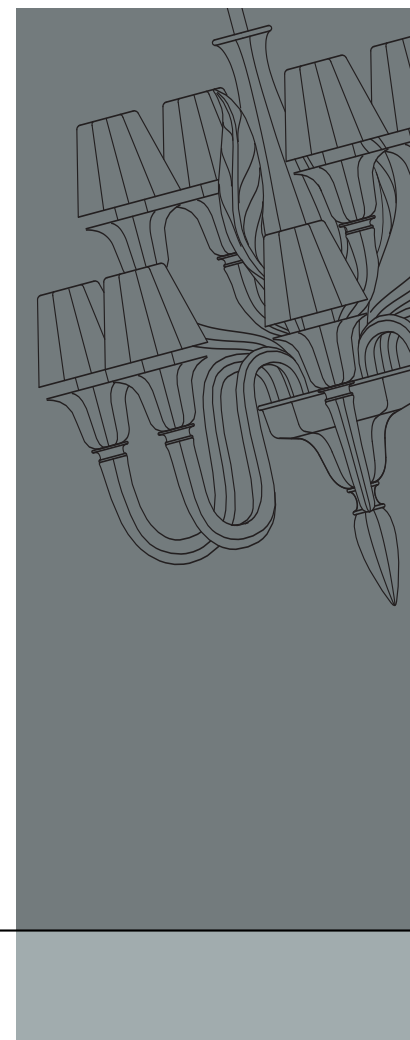

1/6601/5

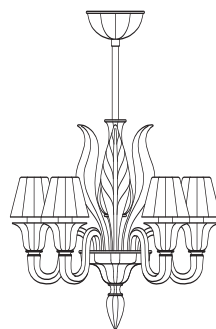

TYPE

chandelier 5 lights

COLOURS AVAILABLE

- cod. **01** clear glass
- cod. **83** transparent red glass
- cod. **85** shiny black glass
- cod. **106** pearly glass
- cod. **107** milky white submerged into clear glass

LAMPSHADES

The clear glass chandelier is provided with a double kit of lampshades formed by a kit of shades in plissé silk – natural colour – and a kit of shades in clear sandblasted glass.

The transparent red glass chandelier is provided with a double kit of lampshades formed by a kit of shades in plissé silk – red colour – and a kit of shades in sandblasted red glass.

The shiny black glass chandelier is provided only with one kit of shades in plissé silk – black colour.

The pearly glass chandelier is provided with a double kit of lampshades formed by a kit of shades in plissé silk – natural colour – and a kit of shades in pearly sandblasted glass.

The milky white chandelier is provided only with one kit of shades in plissé silk – white colour.

FRAME

shiny chrome

SUGGESTED BULBS

n. 5 sphere bulbs E14 x 40 watt max
US market: n.5 bulbs E12 x 40 watt max

HEIGHT

cm 75 - 30"

DIAMETER

cm 55 – 22"

WEIGHT

kg 10

TIPOLOGIA

Lampadario 5 luci

COLORI DISPONIBILI

- cod. **01** cristallo veneziano trasparente
- cod. **83** vetro rosso trasparente
- cod. **85** vetro nero lucido
- cod. **106** vetro perlaceo
- cod. **107** vetro bianco latte sommerso nel cristallo trasparente

PARALUMI

Il lampadario in cristallo veneziano trasparente è fornito con un doppio set di paralumi costituito da un set di paralumi in seta plissé colore naturale e un set di paralumi in cristallo trasparente sabbiato.

Il lampadario in vetro rosso trasparente è fornito con un doppio set di paralumi costituito da un set di paralumi in seta plissé colore rosso e un set di paralumi in vetro rosso sabbiato.

Il lampadario in vetro nero lucido è fornito unicamente con un set di paralumi in seta plissé colore nero.

Il lampadario in vetro perlaceo è fornito con un set di paralumi in seta plissé - colore naturale - e un set di paralumi in vetro perlaceo sabbiato.

Il lampadario in bianco latte è fornito unicamente con un set di paralumi in seta plissé – color bianco.

MONTATURA

cromo lucido

LAMPADINE SUGGERITE

n. 5 lampadine a sfera E14 x 40 watt massimo

ALTEZZA

cm 75 - 30"

DIAMETRO

cm 55 – 22"

PESO

kg 10

1/6601/8

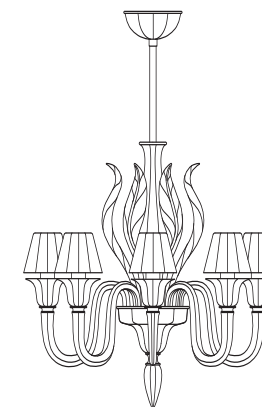

TYPE

chandelier 8 lights

COLOURS AVAILABLE

- cod. **01** clear glass
- cod. **83** transparent red glass
- cod. **85** shiny black glass
- cod. **106** pearly glass
- cod. **107** milky white submerged into clear glass

LAMPSHADES

The clear glass chandelier is provided with a double kit of lampshades formed by a kit of shades in plissé silk – natural colour – and a kit of shades in clear sandblasted glass.

The transparent red glass chandelier is provided with a double kit of lampshades formed by a kit of shades in plissé silk – red colour – and a kit of shades in sandblasted red glass.

The shiny black glass chandelier is provided only with one kit of shades in plissé silk – black colour.

The pearly glass chandelier is provided with a double kit of lampshades formed by a kit of shades in plissé silk – natural colour – and a kit of shades in pearly sandblasted glass.

The milky white chandelier is provided only with one kit of shades in plissé silk – white colour.

FRAME

shiny chrome

SUGGESTED BULBS

n. 8 sphere bulbs E14 x 40 watt max
US market: n.8 bulbs E12 x 40 watt max

HEIGHT

cm 100 – 40"

DIAMETER

cm 65 – 25"

WEIGHT

kg 14

TIPOLOGIA

Lampadario 8 luci

COLORI DISPONIBILI

- cod. **01** cristallo veneziano trasparente
- cod. **83** vetro rosso trasparente
- cod. **85** vetro nero lucido
- cod. **106** vetro perlaceo
- cod. **107** vetro bianco latte sommerso nel cristallo trasparente

PARALUMI

Il lampadario in cristallo veneziano trasparente è fornito con un doppio set di paralumi costituito da un set di paralumi in seta plissé colore naturale e un set di paralumi in cristallo trasparente sabbiato.

Il lampadario in vetro rosso trasparente è fornito con un doppio set di paralumi costituito da un set di paralumi in seta plissé colore rosso e un set di paralumi in vetro rosso sabbiato.

Il lampadario in vetro nero lucido è fornito unicamente con un set di paralumi in seta plissé colore nero.

Il lampadario in vetro perlaceo è fornito con un set di paralumi in seta plissé - colore naturale - e un set di paralumi in vetro perlaceo sabbiato.

Il lampadario in bianco latte è fornito unicamente con un set di paralumi in seta plissé color bianco.

MONTATURA

cromo lucido

LAMPADINE SUGGERITE

n. 8 lampadine a sfera E14 x 40 watt massimo.

ALTEZZA

cm 100 – 40"

DIAMETRO

cm 65 – 25"

PESO

kg 14

1/6601/8+4

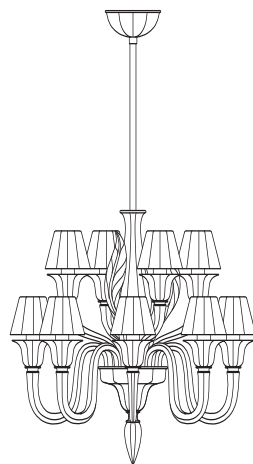

TYPE

chandelier 8+4 lights

COLOURS AVAILABLE

- cod. **01** clear glass
- cod. **83** transparent red glass
- cod. **85** shiny black glass
- cod. **106** pearly glass
- cod. **107** milky white submerged into clear glass

LAMPSHADES

The clear glass chandelier is provided with a double kit of lampshades formed by a kit of shades in plissé silk – natural colour – and a kit of shades in clear sandblasted glass.

The transparent red glass chandelier is provided with a double kit of lampshades formed by a kit of shades in plissé silk – red colour – and a kit of shades in sandblasted red glass.

The shiny black glass chandelier is provided only with one kit of shades in plissé silk – black colour.

The pearly glass chandelier is provided with a double kit of lampshades formed by a kit of shades in plissé silk – natural colour – and a kit of shades in pearly sandblasted glass.

The milky white chandelier is provided only with one kit of shades in plissé silk – white colour.

FRAME

shiny chrome

SUGGESTED BULBS

n. 12 sphere bulbs E14 x 40 watt max
US market: n. 12 bulbs E12 x 40 watt max

HEIGHT

cm 120 – 40"

DIAMETER

cm 65 – 25"

WEIGHT

kg 18

TIPOLOGIA

lampadario 8+4 luci

COLORI DISPONIBILI

- cod. **01** cristallo veneziano trasparente
- cod. **83** vetro rosso trasparente
- cod. **85** vetro nero lucido
- cod. **106** vetro perlaceo
- cod. **107** vetro bianco latte sommerso nel cristallo trasparente

PARALUMI

Il lampadario in cristallo trasparente è fornito con un doppio set di paralumi costituito da un set di paralumi in seta plissé colore naturale e un set di paralumi in cristallo trasparente sabbiato.

Il lampadario in vetro rosso trasparente è fornito con un doppio set di paralumi costituito da un set di paralumi in seta plissé colore rosso e un set di paralumi in vetro rosso sabbiato.

Il lampadario in vetro nero lucido è fornito unicamente con un set di paralumi in seta plissé colore nero.

Il lampadario in vetro perlaceo è fornito con un set di paralumi in seta plissé - colore naturale - e un set di paralumi in vetro perlaceo sabbiato.

Il lampadario in bianco latte è fornito unicamente con un set di paralumi in seta plissé color bianco.

MONTATURA

cromo lucido

LAMPADINE SUGGERITE

n. 12 lampadine a sfera E14 x 40 watt massimo

ALTEZZA

cm 120 – 40"

DIAMETRO

cm 65 – 25"

PESO

kg 18

5/6601/1

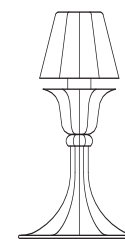

TYPE

Bed side lamp 1 light

COLOURS AVAILABLE

- cod. **01** clear glass
- cod. **83** transparent red glass
- cod. **85** shiny black glass
- cod. **106** pearly glass
- cod. **107** milky white submerged into clear glass

LAMPSHADES

The clear glass chandelier is provided with a double kit of lampshades formed by a kit of shades in plissé silk – natural colour – and a kit of shades in clear sandblasted glass.

The transparent red glass chandelier is provided with a double kit of lampshades formed by a kit of shades in plissé silk – red colour – and a kit of shades in sandblasted red glass.

The shiny black glass chandelier is provided only with one kit of shades in plissé silk – black colour.

The pearly glass chandelier is provided with a double kit of lampshades formed by a kit of shades in plissé silk – natural colour – and a kit of shades in pearly sandblasted glass.

The milky white chandelier is provided only with one kit of shades in plissé silk – white colour.

FRAME

shiny chrome

SUGGESTED BULBS

n. 1 sphere bulbs E14 x 40 watt max
US market: n. 1 bulbs E12 x 40 watt max

HEIGHT

cm 35 – 13"

DIAMETER

cm 12 – 4"

WEIGHT

kg 1

TIPOLOGIA

lumetto 1 luce

COLORI DISPONIBILI

- cod. **01** cristallo veneziano trasparente
- cod. **83** vetro rosso trasparente
- cod. **85** vetro nero lucido
- cod. **106** vetro perlaceo
- cod. **107** vetro bianco latte sommerso nel cristallo trasparente

PARALUMI

Il lampadario in cristallo trasparente è fornito con un doppio set di paralumi costituito da un set di paralumi in seta plissé colore naturale e un set di paralumi in cristallo trasparente sabbiato.

Il lampadario in vetro rosso trasparente è fornito con un doppio set di paralumi costituito da un set di paralumi in seta plissé colore rosso e un set di paralumi in vetro rosso sabbiato.

Il lampadario in vetro nero lucido è fornito unicamente con un set di paralumi in seta plissé colore nero.

Il lampadario in vetro perlaceo è fornito con un set di paralumi in seta plissé - colore naturale - e un set di paralumi in vetro perlaceo sabbiato.

Il lampadario in bianco latte è fornito unicamente con un set di paralumi in seta plissé color bianco.

MONTATURA

cromo lucido

LAMPADINE SUGGERITE

n. 1 lampadine a sfera E14 x 40 watt massimo

ALTEZZA

cm 35 – 13"

DIAMETRO

cm 12 – 4"

PESO

kg 1

6/6608/3

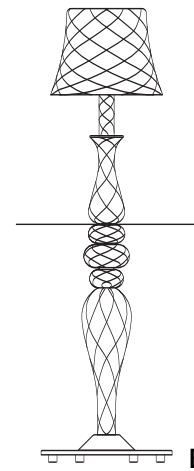
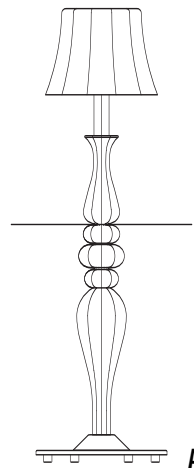

TYPE

Floor lamp with small round coffee table

COLOURS AVAILABLE

cod. **01** clear glass
cod. **83** transparent red glass
cod. **106** pearly glass

GLASS MANUFACTURING

type **A** straight lined
type **B** squared pattern

LAMPSHADES

The clear glass floor lamp is provided with one shade in clear sandblasted glass for type **A**, and one shade in clear transparent glass for type **B**.

The transparent red glass floor lamp is provided with one shade in sandblasted red glass for type **A**, and one shade in transparent red glass for type **B**.

The pearly glass floor lamp is provided with one shade in sandblasted pearly glass for type **A**, and one shade in pearly glass for type **B**.

FRAME – COFFEE TABLE

shiny chrome

SUGGESTED BULBS

n. 3 sphere bulbs E14 x 40 watt max
US market: n.3 bulbs E12 x 40 watt max

HEIGHT

cm 105 – 42"

DIAMETER

cm 42 – 16"

WEIGHT

kg 20

TIPOLOGIA

lampada da terra con piccolo tavolino rotondo

COLORI DISPONIBILI

cod. **01** *cristallo veneziano trasparente*
cod. **83** *vetro rosso trasparente*
cod. **106** *vetro perlaceo*

LAVORAZIONE VETRO

tipo **A** *rigato dritto*
tipo **B** *"ballotton"*

PARALUMI

La lampada da terra in cristallo veneziano trasparente è fornita con un paralume in cristallo trasparente sabbiato per il tipo A e un paralume in cristallo trasparente per il tipo B.

La lampada da terra in vetro rosso trasparente è fornita con un paralume in vetro rosso sabbiato per il tipo A e un paralume in vetro rosso trasparente per il tipo B.

La lampada da terra in vetro perlaceo è fornita con un paralume in vetro perlaceo sabbiato per il tipo A e un paralume in vetro perlaceo per il tipo B.

MONTATURA – TAVOLINO

cromo lucido

LAMPADINE SUGGERITE

n. 3 lampadine a sfera E14 x 40 watt massimo

ALTEZZA

cm 105 – 42"

DIAMETRO

cm 42 – 16"

PESO

kg 20

6/6609/3

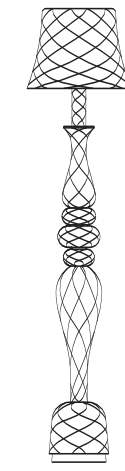
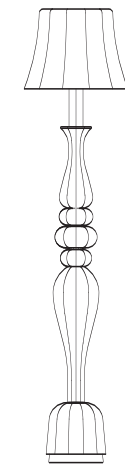

TYPE

Floor lamp

COLOURS AVAILABLE

cod. **01** clear glass
cod. **83** transparent red glass
cod. **106** pearly glass

GLASS MANUFACTURING

type **A** straight lined
type **B** squared pattern

LAMPSHADES

The clear glass floor lamp is provided with one shade in clear sandblasted glass for type **A**, and one shade in clear transparent glass for type **B**.

The transparent red glass floor lamp is provided with one shade in sandblasted red glass for type **A**, and one shade in transparent red glass for type **B**.

The pearly glass floor lamp is provided with one shade in sandblasted pearly glass for type **A**, and one shade in pearly glass for type **B**.

FRAME

shiny chrome

SUGGESTED BULBS

n. 3 sphere bulbs E14 x 40 watt max
US market: n.3 bulbs E12 x 40 watt max

HEIGHT

cm 115 – 45"

DIAMETER

cm 26 – 11"

WEIGHT

kg 20

TIPOLOGIA

lampada da terra

COLORI DISPONIBILI

cod. **01** *cristallo veneziano trasparente*
cod. **83** *vetro rosso trasparente*
cod. **106** *vetro perlaceo*

LAVORAZIONE VETRO

tipo **A** *rigato dritto*
tipo **B** *"ballotton"*

PARALUMI

La lampada da terra in cristallo trasparente è fornita con un paralume in cristallo veneziano sabbiato per il tipo A e un paralume in cristallo veneziano trasparente per il tipo B.

La lampada da terra in vetro rosso trasparente è fornita con un paralume in vetro rosso sabbiato per il tipo A e un paralume in vetro rosso trasparente per il tipo B.

La lampada da terra in vetro perlaceo è fornita con un paralume in vetro perlaceo sabbiato per il tipo A e un paralume in vetro perlaceo per il tipo B.

MONTATURA

cromo lucido

LAMPADINE SUGGERITE

n. 3 lampadine a sfera E14 x 40 watt massimo.

ALTEZZA

cm 115 – 45"

DIAMETRO

cm 26 – 11"

PESO

kg 20



6/6603/9

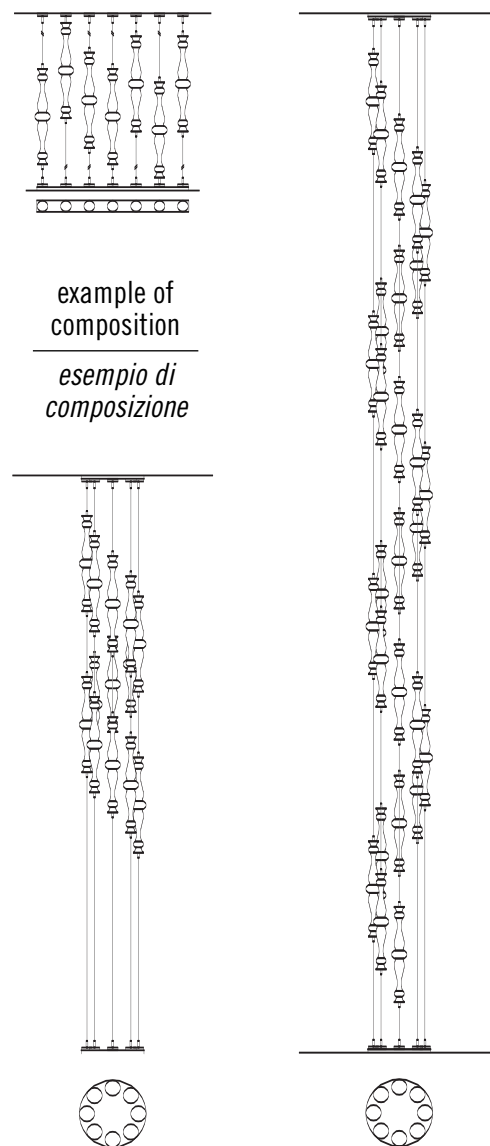
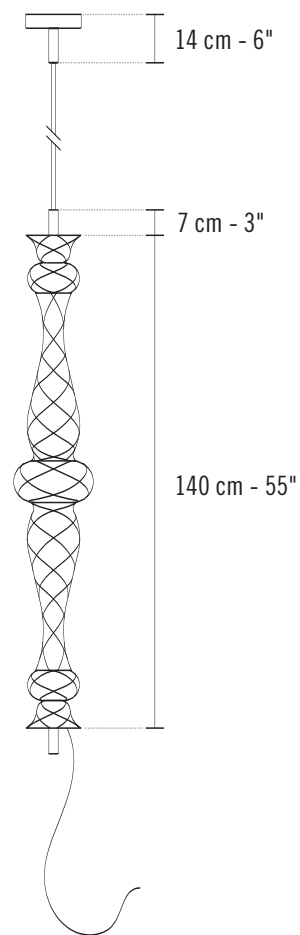

example of
composition
*esempio di
composizione*

102

Technical session

TYPE

Short floating floor lamp, 9 lights

COLOURS AVAILABLE

cod. **01** clear glass
cod. **83** transparent red glass
cod. **106** pearly glass

FRAME

shiny chrome

SUGGESTED BULBS

n. 9 olive opaque bulbs E14 x 25 watt max
US market: n.9 olive opaque bulbs E12 x 40 watt max

HEIGHT OF GLASS LAMP ONLY

cm 140 – 55"

DIAMETER

cm 16 – 7"

WEIGHT

kg 25

TIPOLOGIA

lampada da terra piccola sospesa

COLORI DISPONIBILI

cod. **01** *cristallo veneziano trasparente*
cod. **83** *vetro rosso trasparente*
cod. **106** *vetro perlaceo*

MONTATURA

Cromo lucido

LAMPADINE SUGGERITE

n. 9 lampadine opache a sfera E14 x 25 watt massimo.

ALTEZZA SOLO VETRO

cm 140 – 55"

DIAMETRO

cm 16 – 7"

PESO

kg 25

6/6602/14

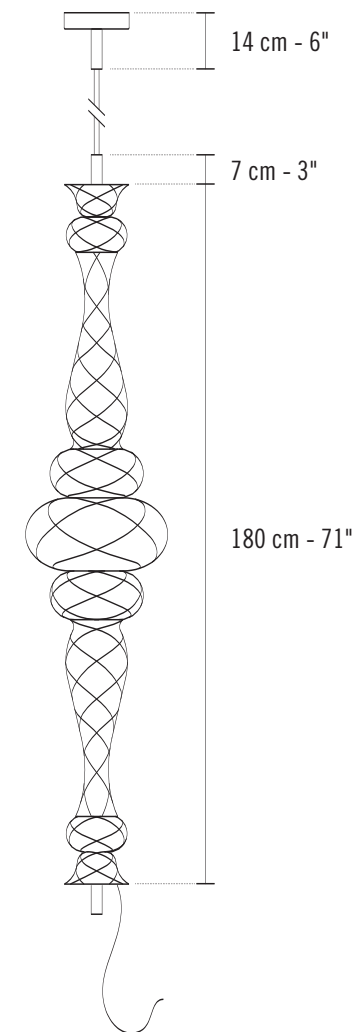

TYPE

Tall floating floor lamp 14 lights

COLOURS AVAILABLE

cod. **01** clear glass
cod. **83** transparent red glass
cod. **106** pearly glass

FRAME

shiny chrome

SUGGESTED BULBS

n. 14 olive opaque bulbs E14 x 25 watt max
US market: n.14 olive opaque bulbs E12 x 40 watt max

HEIGHT OF GLASS LAMP ONLY

cm 180 – 71"

DIAMETER

cm 26 – 11"

WEIGHT

kg 50

TIPOLOGIA

lampada da terra grande sospesa a 14 luci

COLORI DISPONIBILI

cod. **01** *cristallo veneziano trasparente*
cod. **83** *vetro rosso trasparente*
cod. **106** *vetro perlaceo*

MONTATURA

Cromo lucido

LAMPADINE SUGGERITE

n. 14 lampadine opache a sfera E14 x 25 watt massimo.

ALTEZZA SOLO VETRO

cm 180 – 71"

DIAMETRO

cm 26 – 11"

PESO

kg 50



103

Technical session

3/6606/1

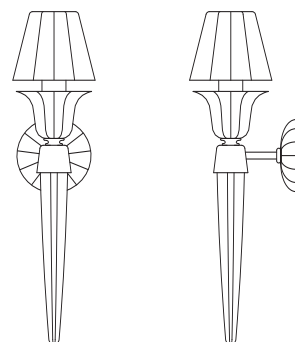

TYPE

Wall bracket 1 light

COLOURS AVAILABLE

- cod. **01** clear glass
- cod. **83** transparent red glass
- cod. **85** shiny black glass
- cod. **106** pearly glass
- cod. **107** milky white submerged into clear glass

LAMPSHADES

The clear glass wall bracket is provided with a double kit of lampshades formed by one shade in plissé silk – natural colour – and one shade in clear sandblasted glass.

The transparent red glass wall bracket is provided with a double kit of lampshades formed by one shade in plissé silk – red colour – and one shade in sandblasted red glass.

The shiny black glass wall bracket is provided only with one kit of shades in plissé silk – black colour.

The pearly glass wall bracket is provided with a double kit of lampshades formed by one shade in plissé silk – natural colour – and one shade in pearly sandblasted glass.

The milky white wall bracket is provided only with one shade in plissé silk – white colour.

FRAME

shiny chrome

SUGGESTED BULBS

n. 1 sphere bulbs E14 x 40 watt max
US market: n. 1 sphere bulbs E12 x 40 watt max

HEIGHT

cm 52 – 20"

DIAMETER

cm 12 – 5"

WIDTH

cm 18 – 7"

WEIGHT

kg 1,5

TIPOLOGIA

Applique 1 luce

COLORI DISPONIBILI

- cod. **01** cristallo veneziano trasparente
- cod. **83** vetro rosso trasparente
- cod. **85** vetro nero lucido
- cod. **106** vetro perlaceo
- cod. **107** vetro bianco latte sommerso nel cristallo trasparente

PARALUMI

L'applique in cristallo trasparente è fornito con un doppio set di paralumi costituito da un paralume in seta plissé colore naturale e un paralume in cristallo trasparente sabbato.

L'applique in vetro rosso trasparente è fornito con un doppio set di paralumi costituito da un paralume in seta plissé colore rosso e un paralume in vetro rosso sabbato.

L'applique in vetro nero lucido è fornito unicamente con un paralume in seta plissé colore nero.

L'applique in vetro perlaceo è fornito con un paralume in seta plissé - colore naturale - e un paralume in vetro perlaceo sabbato.

L'applique in bianco latte è fornito unicamente con un paralume in seta plissé color bianco.

MONTATURA

cromo lucido

LAMPADINE SUGGERITE

n. 1 lampadine a sfera E14 x 40 watt massimo

ALTEZZA

cm 52 – 20"

DIAMETRO

cm 12 – 5"

PROFONDITÀ

cm 18 – 7"

PESO

kg 1,5

3/6605/2

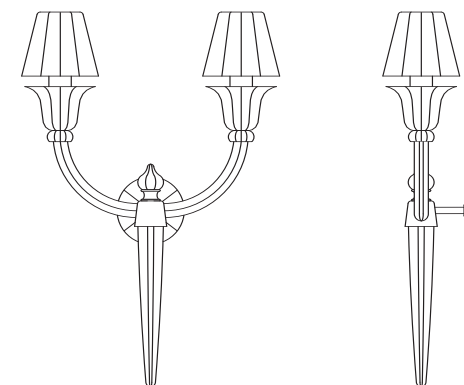

TYPE

Wall bracket 2 lights

COLOURS AVAILABLE

- cod. **01** clear glass
- cod. **83** transparent red glass
- cod. **85** shiny black glass
- cod. **106** pearly glass
- cod. **107** milky white submerged into clear glass

LAMPSHADES

The clear glass wall bracket is provided with a double kit of lampshades formed by a kit of shades in plissé silk – natural colour – and a kit of shades in clear sandblasted glass.

The transparent red glass wall bracket is provided with a double kit of lampshades formed by a kit of shades in plissé silk – red colour – and a kit of shades in sandblasted red glass.

The shiny black glass chandelier is provided only with one kit of shades in plissé silk – black colour.

The pearly glass wall bracket is provided with a double kit of lampshades formed by a kit of shades in plissé silk – natural colour – and a kit of shades in pearly sandblasted glass.

The milky white wall bracket is provided only with one kit of shades in plissé silk – white colour.

FRAME

shiny chrome

SUGGESTED BULBS

n. 2 sphere bulbs E14 x 40 watt max
US market: n. 2 sphere bulbs E12 x 40 watt max

HEIGHT

cm 60 – 24"

DIAMETER

cm 40 – 16"

WIDTH

cm 18 – 7"

WEIGHT

kg 3

TIPOLOGIA

Applique 2 luci

COLORI DISPONIBILI

- cod. **01** cristallo veneziano trasparente
- cod. **83** vetro rosso trasparente
- cod. **85** vetro nero lucido
- cod. **106** vetro perlaceo
- cod. **107** vetro bianco latte sommerso nel cristallo trasparente

PARALUMI

L'applique in cristallo veneziano trasparente è fornito con un doppio set di paralumi costituito da un set di paralumi in seta plissé colore naturale e un set di paralumi in cristallo trasparente sabbato.

L'applique in vetro rosso trasparente è fornito con un doppio set di paralumi costituito da un set di paralumi in seta plissé colore rosso e un set di paralumi in vetro sabbato.

L'applique in vetro nero lucido è fornito unicamente con un set di paralumi in seta plissé colore nero.

L'applique in vetro perlaceo è fornito con un set di paralumi in seta plissé - colore naturale - e un set di paralumi in vetro perlaceo sabbato.

L'applique in bianco latte è fornito unicamente con un set di paralumi in seta plissé color bianco.

MONTATURA

cromo lucido

LAMPADINE SUGGERITE:

n. 2 lampadine a sfera E14 x 40 watt massimo

ALTEZZA

cm 60 – 24"

DIAMETRO

cm 40 – 16"

PROFONDITÀ

cm 18 – 7"

PESO

kg 3

3/6604/1

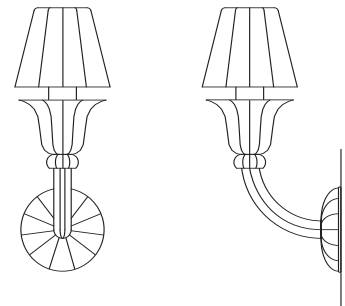

TYPE

Wall bracket 1 light

COLOURS AVAILABLE

- cod. 01 clear glass
- cod. 83 transparent red glass
- cod. 85 shiny black glass
- cod. 106 pearly glass
- cod. 107 milky white submerged into clear glass

LAMPSHADES

The clear glass wall bracket is provided with a double kit of lampshades formed by one shade in plissé silk – natural colour – and one shade in clear sandblasted glass.

The transparent red glass wall bracket is provided with a double kit of lampshades formed by one shade in plissé silk – red colour – and one shade in sandblasted red glass.

The shiny black glass wall bracket is provided only with one kit of shades in plissé silk – black colour.

The pearly glass wall bracket is provided with a double kit of lampshades formed by one shade in plissé silk – natural colour – and one shade in pearly sandblasted glass.

The milky white wall bracket is provided only with one shade in plissé silk – white colour.

FRAME

shiny chrome

SUGGESTED BULBS

n. 1 sphere bulbs E14 x 40 watt max
US market: n.1 sphere bulbs E12 x 40 watt max

HEIGHT

cm 35 – 14"

DIAMETER

cm 13 – 5"

WIDTH

cm 20 – 8"

WEIGHT

kg 1

TIPOLOGIA

Applique 1 luce

COLORI DISPONIBILI

- cod. 01 cristallo veneziano trasparente
- cod. 83 vetro rosso trasparente
- cod. 85 vetro nero lucido
- cod. 106 vetro perlaceo
- cod. 107 vetro bianco latte sommerso nel cristallo trasparente

PARALUMI

L'applique in cristallo veneziano trasparente è fornito con un doppio set di paralumi costituito da un paralume in seta plissé colore naturale e un paralume in cristallo trasparente sabbiato.

L'applique in vetro rosso trasparente è fornito con un doppio set di paralumi costituito da un paralume in seta plissé colore rosso e un paralume in vetro rosso sabbiato.

L'applique in vetro nero lucido è fornito unicamente con un paralume in seta plissé colore nero.

L'applique in vetro perlaceo è fornito con un paralume in seta plissé - colore naturale - e un paralume in vetro perlaceo sabbiato.

L'applique in bianco latte è fornito unicamente con un paralume in seta plissé color bianco.

MONTATURA

cromo lucido

LAMPADINE SUGGERITE

n. 1 lampadine a sfera E14 x 40 watt massimo

ALTEZZA

cm 35 – 14"

DIAMETRO

cm 13 – 5"

PROFONDITÀ

cm 20 – 8"

PESO

kg 1

3/6601/3

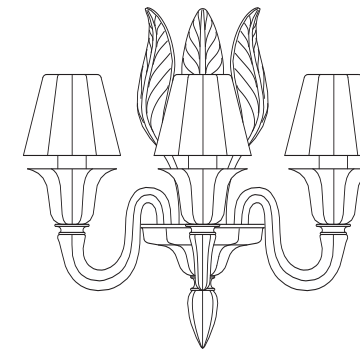

TYPE

Wall bracket 3 lights

COLOURS AVAILABLE

- cod. 01 clear glass
- cod. 83 transparent red glass
- cod. 85 shiny black glass
- cod. 106 pearly glass
- cod. 107 milky white submerged into clear glass

LAMPSHADES

The clear glass wall bracket is provided with a double kit of lampshades formed by a kit of shades in plissé silk – natural colour – and a kit of shades in clear sandblasted glass.

The transparent red glass wall bracket is provided with a double kit of lampshades formed by a kit of shades in plissé silk – red colour – and a kit of shades in sandblasted red glass.

The shiny black glass wall bracket is provided only with one kit of shades in plissé silk – black colour.

The pearly glass wall bracket is provided with a double kit of lampshades formed by a kit of shades in plissé silk – natural colour – and a kit of shades in pearly sandblasted glass.

The milky white wall bracket is provided only with one kit of shades in plissé silk – white colour.

FRAME

shiny chrome

SUGGESTED BULBS

n. 3 sphere bulbs E14 x 40 watt max
US market: n.3 sphere bulbs E12 x 40 watt max

HEIGHT

cm 45 – 18"

DIAMETER

cm 45 – 18"

WIDTH

cm 25 – 10"

WEIGHT

kg 7

TIPOLOGIA

Applique 3 luci

COLORI DISPONIBILI

- cod. 01 cristallo veneziano trasparente
- cod. 83 vetro rosso trasparente
- cod. 85 vetro nero lucido
- cod. 106 vetro perlaceo
- cod. 107 vetro bianco latte sommerso nel cristallo trasparente

PARALUMI

L'applique in cristallo veneziano trasparente è fornito con un doppio set di paralumi costituito da un set di paralumi in seta plissé colore naturale e un set di paralumi in cristallo trasparente sabbiato.

L'applique in vetro rosso trasparente è fornito con un doppio set di paralumi costituito da un set di paralumi in seta plissé colore rosso e un set di paralumi in vetro rosso sabbiato.

L'applique in vetro nero lucido è fornito unicamente con un set di paralumi in seta plissé colore nero.

L'applique in vetro perlaceo è fornito con un set di paralumi in seta plissé - colore naturale - e un set di paralumi in vetro perlaceo sabbiato.

L'applique in bianco latte è fornito unicamente con un set di paralumi in seta plissé color bianco.

MONTATURA

cromo lucido

LAMPADINE SUGGERITE

n. 3 lampadine a sfera E14 x 40 watt massimo

ALTEZZA

cm 45 – 18"

DIAMETRO

cm 45 – 18"

PROFONDITÀ

cm 25 – 10"

PESO

kg 7

5/6607/8

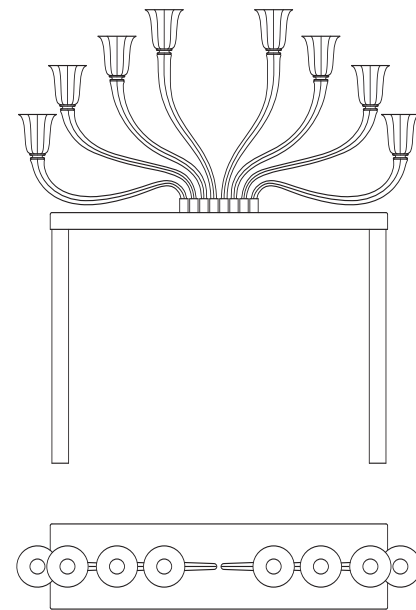

TYPE

Table 8 lights

- cod. **01** clear glass
- cod. **83** transparent red glass
- cod. **85** shiny black glass
- cod. **106** pearly glass
- cod. **107** milky white submerged into clear glass

FRAME – TABLE

shiny chrome

SUGGESTED BULBS

n. 8 sphere bulbs E14 x 40 watt max
US market: n.8 sphere bulbs E12 x 40 watt max

LENGTH

cm 120 – 48"

HEIGHT

cm 136 – 54"

WIDTH

cm 26 – 11"

WEIGHT

kg 40

This item may be realized only for candle-holders up on request.

TIPOLOGIA

tavolo a 8 luci

- cod. **01** cristallo veneziano trasparente
- cod. **83** vetro rosso trasparente
- cod. **85** vetro nero lucido
- cod. **106** vetro perlaceo
- cod. **107** vetro bianco latte sommerso nel cristallo trasparente

MONTATURA – TAVOLO

cromo lucido

LAMPADINE SUGGERITE

n. 8 lampadine a sfera E14 x 40 watt massimo

LUNGHEZZA

cm 120 – 48"

ALTEZZA

cm 136 – 54"

PROFONDITÀ

cm 26 – 11"

PESO

kg 40

Su richiesta questo articolo può essere realizzato solo per candele.

HOW TO READ A CODE

TYPE OF FIXTURE

XX/xxxx/xx/xx/xx

The first number of an article identifies the type of fixture:

- 1 Chandelier
- 3 Wall bracket
- 5 Bed side lamp – Enlightened furniture
- 6 Floor lamp – Floating floor lamp

ARTICLE NUMBER

xx/XXXX/xx/xx/xx

The second number of an article it's the number of the article itself

GLASS CODE

x/xxxx/XX/xx/xx

The third number of an article identifies the glass colour:

- 01** Clear glass
- 83** Transparent red glass
- 85** Shiny black glass
- 106** Pearly glass
- 107** Milky white submerged into clear glass

FRAME CODE

xx/xxxx/xx/XX/xx

The fourth number of an article identifies the frame:

- 02** Shiny chrome

LIGHTS

xx/xxxx/xx/xx/XX

The last number of an article identifies the quantity of lights

COME LEGGERE UN CODICE ARTICOLO

TIPOLOGIA DI LAMPADA

XX/xxxx/xx/xx/xx

Il primo numero di un articolo identifica la tipologia di lampada:

- 1 Lampadario
- 3 Applique
- 5 Lumetto – tavolo
- 6 Lampada da terra – Lampada da terra sospesa

NUMERO ARTICOLO

xx/XXXX/xx/xx/xx

Il secondo numero di un articolo è il numero dell'articolo stesso

CODICE VETRO

x/xxxx/XX/xx/xx

Il terzo numero di un articolo identifica il colore del vetro:

- 01** Cristallo veneziano trasparente
- 83** Vetro rosso trasparente
- 85** Vetro nero lucido
- 106** Vetro perlaceo
- 107** Vetro bianco latte sommerso nel cristallo trasparente

CODICE MONTATURA

xx/xxxx/xx/XX/xx

Il quarto numero di un articolo identifica il tipo di montatura:

- 02** Cromo lucido

LUCI

xx/xxxx/xx/xx/XX

L'ultimo numero di un articolo identifica la quantità di luci

the Mist

for individual contemplation only - *da contemplare in solitario*
A collection by Andromeda International - *Una collezione di Andromeda International*

Design:
Leo De Carlo

ANDROMEDA INTERNATIONAL

Chairman - *Presidente:*
Gianluca Vecchi

Commercial network - *Network commerciale*
U.S.A.

Leucos U.S.A. Inc.
Edison (NJ - U.S.A.)

Josie Anthony (Chairman)
info@leucosusa.com

ph.+1.732.2250010 - fax +1.732.2250250

U.K. - Ireland Office - *Ufficio per la Gran Bretagna e l'Irlanda*

Manager: Paolo Cassina

paolo.cassina@btinternet.com

mobile ++44.77.78576472 - fax ++44.208.4551843

Inside sales manager - *Responsabili vendita interni*

Halyna Znamerovska

Russia - Ukraine - Belarus - Estonia - Latvia - Lithuania - Czech Republic

halyna@andromedamurano.it

Sara Zuliani

Italia - France - Spain - Greece - Belgium - Switzerland

sara@andromedamurano.it

Marco D'Addona

Italia - Austria - Germany - Netherlands

marco@andromedamurano.it

Other countries should enquire to - *Altri paesi si rivolgano a:*

Director of Marketing & Business Development - *Direttore Marketing & Sviluppo Mercati*

Marzia Vianello

marzia@andromedamurano.it

special thanks to - *un ringraziamento speciale a:*

Alberto Furtak - Technical development

Michela Vianello - Artist

Shutterstock, Inc.

Evgeny E. Kuklev

Nick Stubbs

Ong Yoong Seang

Anita

Amparo Fontanet

ANDROMEDA
i n t e r n a t i o n a l

ANDROMEDA INTERNATIONAL s.r.l.

calle Miotti, 16 - 30141 Murano, Venezia / Italia

tel. +39 041 736674 - fax +39 041 5274453

www.andromedamurano.it

e-mail: info@andromedamurano.it



The Vetro Artistico di Murano trademark is granted to carefully selected companies, based on strict criteria. A highly qualified technical and scientific commission keeps the use of the trademark constantly under control. Only authentic products and glassmakers whose work is based on the original Muranese glassmaking traditions are authorized to display the trademark.

Creation and general coordination - *Ideazione e coordinamento generale:*

Diego Lazzarini Design - Venezia

info@diegolazzarinidesign.com

General lay-out - *Progetto grafico:*

Diego Lazzarini Design - Venezia

Contributions by - *Collaboratori:*

Pietro Menozzi

Giovanni Lazzarini

Photographs by - *Fotografie:*

© Diego Lazzarini 2006 - all rights reserved

Diego Lazzarini Design - Venezia

Texts - *Testi:*

Marzia Vianello

Translation from english to italian - *Traduzione dall'inglese all'italiano:*

Studio Ter Traduzioni

No part of this publication may be reproduced, stored in a retrieval system, or transmitted in any form or by any means without permission in writing of copyright holders.

Nessuna parte di questo catalogo può essere riprodotta o trasmessa in qualsiasi forma o con qualsiasi mezzo elettronico, meccanico o altro, senza l'autorizzazione dei proprietari dei diritti.

All the products shown in this publication are registered products of Andromeda International

Tutti i prodotti di questo catalogo sono prodotti registrati Andromeda International

ANDROMEDA



www.andromedamurano.it

ANDROMEDA