

MOROSINI[®]
luce & design

NEWS
2017

Evi Style[®]

MOROSINI[®]
luce & design





VANE

design ● Romani Saccani
Architetti Associati

Connubio di geometrie
protagoniste
in ogni contesto

Combination of geometries
which become protagonists
in each context



Vane_PA1





Come il segnavento da cui eredita il nome, Vane trova la sua naturale collocazione nei punti chiave dello spazio in cui si inserisce.

Dalla fusione di due geometrie nasce una lampada da parete dalle caratteristiche minimali che spicca per equilibrio delle forme e per funzionalità. La sorgente led, disposta "a bandiera" rispetto alla parete, proietta una luce che è possibile ruotare di 325 gradi, offrendo così una varietà di utilizzo modulabile secondo ogni esigenza. In quest'ottica è stata progettata la sagoma dell'impugnatura, studiata per garantire elevati standard di ergonomia e maneggevolezza. Una dinamicità che trova la sua naturale collocazione sia in ambienti domestici che in contesti contract. L'apparecchio è dimmerabile Triac.

Comme la girouette dont elle tient le nom, Vane est naturellement destinée aux points-clés de l'espace dans lequel on l'installe.

La fusion de deux géométries a donné naissance à une applique aux caractéristiques minimales qui se distingue par l'équilibre des formes et par sa fonctionnalité. La source led, disposée "en drapeau" par rapport au mur, projette une lumière qui peut pivoter de 325°, offrant une variété d'utilisation modulable en fonction des besoins. C'est dans cette optique que l'on a façonné une poignée en mesure de garantir de hauts standards d'ergonomie et de maniabilité. Un dynamisme qui s'intègre avec naturel dans les espaces domestiques et des collectivités. L'appareil est dimmable Triac.

Vane, whose name derives from the weather vane, wherever it is placed it finds its natural space.

This wall lamp arises from the merger of two geometries with minimal features and stands out for the formal balance and functionality.

The source led, placed as a "flag" to the wall, beams a light that can be rotated 325 degrees, providing a variety of uses modulated according to all needs. In order to reach this modularity, the grip has a specific shape, designed to ensure high ergonomic and handling standards. A dynamic that finds its natural place both in private and public use. The device is dimmable Triac.

Como la veleta de la que hereda su nombre, Vane encuentra su colocación natural en cualquier sitio se ponga.

De la unión entre dos geometrías, nace una lámpara de pared que sobresale por su carácter minimal, su equilibrio de formas y su funcionalidad.

La fuente led, que se dispone a bandera con respecto a la pared, proyecta una luz que se puede girar de 325°, ofreciendo una variedad de usos que se ajustan a las necesidades. En esta óptica se ha diseñado el perfil de la empuñadura, estudiada para garantizar altos estándares de ergonomía y manejabilidad. Ese dinamismo permite colocarla en entornos tanto domésticos como de contract. El aparato es regulable Triac.

Wie die Windfahne, von der sie ihren Namen erhält, findet Vane ihren natürlichen Einsatz in den Schlüsselpunkten des Raums, in den sie eingegliedert wird.

Aus der Verbindung zweier Geometrien entstand eine Wandlampe mit Minimal-Eigenschaften, die dank des Ausgleichs der Formen und der Funktion herausragt. Die Led-Lichtquelle, die gegenüber der Wand „wie eine Fahne“ angeordnet ist, projiziert ein Licht, das um 325 Grad gedreht werden kann, wodurch eine veränderbare Nutzung je nach Anforderung möglich ist. In diesem Rahmen wurde die Form des Griffs entworfen, um eine hohe Ergonomie und eine einfache Bedienung zu gewährleisten. Eine Dynamik, die ihre natürliche Anordnung im Haus wie in Contract-Umgebungen findet. Das Gerät ist über Triac dimmbar.

Vane - в переводе флюгер, где бы ни находился, везде находит для себя подходящее пространство.

Это бра возникает в результате слияния двух геометрических форм, с минимальным количеством особенностей и выделяется своим балансом и функциональностью.

Светодиодный источник света закреплён на стене как флажок, дающий на стену луч света и вращающийся на 325 градусов, обеспечивает множество возможных применений. Для того, чтобы достичь такой вариативности, «голове» светильника придали специальную форму, обеспечивающую высокую эргономичность. Такой функциональности найдётся применение как в частном, так и в общественном интерьере. Светильник может диммироваться с помощью TRIAC.

Struttura: metallo nelle colorazioni: bianco opaco, nero opaco, oro opaco, rame opaco.

Diffusore: Policarbonato satinato.

Frame: metal in the colors: matt white, matt black, matt gold, matt copper.

Diffuser: Polycarbonate satin finish.

Struktur: Metall in den Farben: Mattweiß, Mattschwarz, Mattgold, Mattkupfer.

Diffusor: Satiniertes Polycarbonat.

Structure: métal dans les teintes: blanc mat, noir mat, or mate, cuivre mat.

Diffusor: Polycarbonate satiné.

Estructura: metal in los colores: blanco mate, negro mate, oro mate, cobre mate.

Difusor: Policarbonato satinado.

Структура: металл окрашенный в матовый белый, матовый чёрный, матовый золотой или матовый медный цвет.

Рассеиватель: матовый поликарбонат



BI: Bianco opaco/
Matt White



NE: Nero opaco/
Matt Black



OR: Oro opaco/
Matt Gold



RA: Rame opaco/
Matt copper

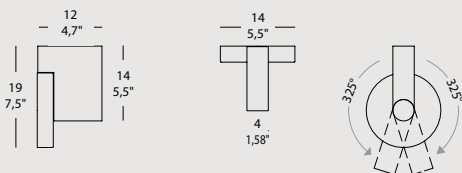

VANE PA1

10W 950 Lm 2700K Cri>80 Acrich 3 LED

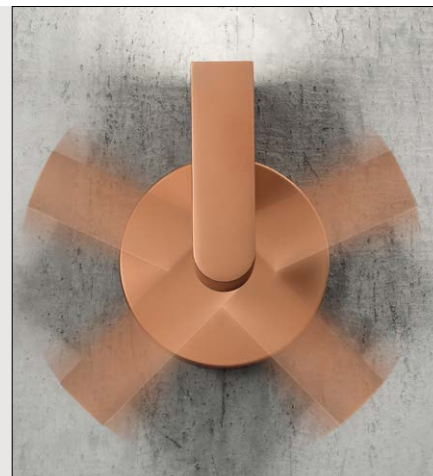
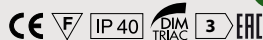

- Modello Europeo Registrato
- European Registered Design

Santral rivoluziona l'estetica classica dei lampadari a sospensione. La collezione è altamente personalizzabile nel design grazie ai cavi indipendenti con i quali è possibile creare infinite composizioni sia all'interno dello spazio circoscritto del rosone, sia liberamente all'esterno per mezzo di ancoraggi fissati al soffitto.

Si ottiene così un oggetto d'arredo capace di caratterizzare con formalità e assoluta originalità sia location circoscritte che ambienti spaziosi. Di facile installazione grazie ad un sistema di jack, Santral prevede sorgenti a LED racchiuse in particolari metallici di forma conica, disponibili anche con diffusore in vetro soffiato satinato che impreziosisce ulteriormente la collezione.

Santral bouleverse l'esthétique classique des lustres à suspension. La collection est hautement personnalisable au niveau du design grâce aux câbles indépendants avec lesquels on peut créer d'infinies compositions à l'intérieur de l'espace circonscrit de la plaque ronde, et librement à l'extérieur au moyen d'ancrages fixés au plafond.

On obtient ainsi un objet de décoration capable de caractériser avec une formalité et une originalité absolue des espaces circonscrits et des pièces spacieuses.

Facile à installer grâce à un système de jacks, Santral prévoit des sources à LED contenues dans des éléments métalliques de forme conique, également fournis avec un diffuseur en verre soufflé satiné qui enrichit ultérieurement la collection.

Santral revolutionizes the classic aesthetics of pendant chandeliers. The collection is highly customizable in design thanks to independent cables with which you can create endless compositions within the ceiling rose of the lamp, but also outside of it, through anchors that are fixed to the ceiling.

The result is a piece of furniture able to give formality and absolute originality to small locations but also to big spaces. Thanks to a system of jacks, Santral is easy to be installed and provides LED sources which are inside of conical metallic elements, also available with a diffuser in blown glass that further enhances the collection.

Santral revoluciona la estética clásica de las arañas.

La colección es perfectamente personalizable en el design gracias a los cables independientes con los cuales es posible crear infinitas composiciones tanto en el interior del espacio circunscrito del rosetón como libremente en el exterior por medio de anclajes fijados al techo.

Se obtiene así un objeto de decoración en condiciones de caracterizar con formalidad y absoluta originalidad tanto lugares circunscritos como ambientes espaciosos.

De fácil instalación gracias a un sistema de jack, Santral prevé fuentes de LED encerradas en detalles metálicos de forma cónica, disponibles incluso con difusor de vidrio soplado satinado que valoriza ulteriormente la colección.

Santral revolutioniert die klassische Ästhetik der Hängelampen.

Die Kollektion ist durch unabhängige Kabel vielseitig im Design personalisierbar. Mit diesen kann man unzählige Kompositionen erstellen, im engen Inneren der Rosette, aber auch bequem aussen durch Deckenbefestigungen. Dadurch entsteht ein Einrichtungsgegenstand, der durch seine Formalität und absolute Originalität in engen Räumen, wie auch geräumigen Umgebungen besticht. Mit einem einfachen Buchsen-Montagesystem ausgestattet, sieht Santral LED-Lichtquellen vor, die in metallische Teile mit konischer Form eingeschlossen sind. Erhältlich auch mit Diffusor aus satiniertem und geblasenem Glas, das die Kollektion nochmals erheblich aufwertet.

Santral производит коренной переворот в классической эстетике подвесных светильников. Коллекция обладает большими возможностями персонализации дизайна, благодаря отдельным проводам, с помощью которых возможно создать бесконечное множество композиций, как внутри пространства, ограниченного потолочной чашей, так и снаружи с помощью потолочных анкеров.

Таким образом, создается предмет обстановки, способный охарактеризовать формально и с абсолютной оригинальностью как ограниченные пространства, так и просторные помещения.

Легко монтируется благодаря системе jack, Santral предусматривает источники света LED, заключенные в металлические элементы конической формы, которые также могут быть предложены с рассеивателем из дутого сатирированного стекла, придающего коллекции дополнительную ценность.

Struttura: metallo nero opaco.

Diffusore: vetro satinato.

Frame: matt black metal.

Diffuser: satin glass.

Struktur: Metall, mattschwarz.

Difusor: Satiniertes Glas.

Structure: métal noir mat.

Diffusor: verre satiné.

Estructura: metal negro opaco.

Difusor: vidrio satinado.

Структура: металл, выполняется в черном матовом цвете.

Рассеиватель: Сатирированное стекло.

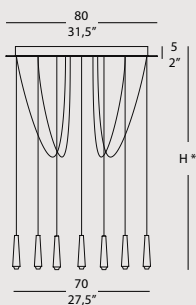

SANTRAL LA 8 GLASS_S

Cavo/cable standard cm 200/78,8"

8 x 3,2W 2840 Lm 3000K Cri>80 220/240V

8 x 3,2W 2680 Lm 2700K Cri>80 220/240V **LED**

SANTRAL LA 8 GLASS_S DIM PD

8 x 3,2W 2840 Lm 3000K Cri>80 220/240V

8 x 3,2W 2680 Lm 2700K Cri>80 220/240V

con driver dimmerabile push/with push dimmable driver 220/240V **LED**

CE

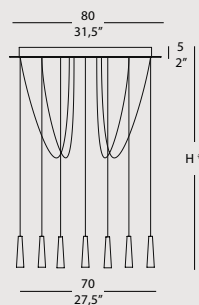

SANTRAL LA 8_S

Cavo/cable standard cm 200/78,8"

8 x 3,2W 2840 Lm 3000K Cri>80 220/240V

8 x 3,2W 2680 Lm 2700K Cri>80 220/240V **LED**

SANTRAL LA 8_S DIM PD

8 x 3,2W 2840 Lm 3000K Cri>80 220/240V

8 x 3,2W 2680 Lm 2700K Cri>80 220/240V

con driver dimmerabile push/with push dimmable driver 220/240V **LED**

CE

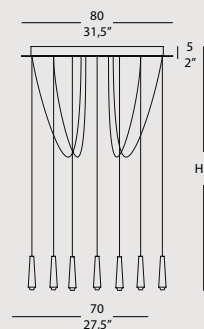

SANTRAL LA 8 GLASS_L

Cavo/cable standard cm 280/110,2"

8 x 3,2W 2840 Lm 3000K Cri>80 220/240V

8 x 3,2W 2680 Lm 2700K Cri>80 220/240V **LED**

SANTRAL LA 8 GLASS_L DIM PD

8 x 3,2W 2840 Lm 3000K Cri>80 220/240V

8 x 3,2W 2680 Lm 2700K Cri>80 220/240V

con driver dimmerabile push/with push dimmable driver 220/240V **LED**

CE

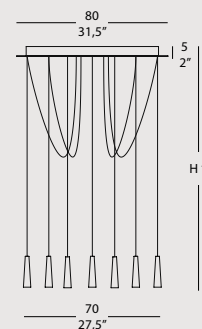

SANTRAL LA 8_L

Cavo/cable standard cm 280/110,2"

8 x 3,2W 2840 Lm 3000K Cri>80 220/240V

8 x 3,2W 2680 Lm 2700K Cri>80 220/240V **LED**

SANTRAL LA 8_L DIM PD

8 x 3,2W 2840 Lm 3000K Cri>80 220/240V

8 x 3,2W 2680 Lm 2700K Cri>80 220/240V

con driver dimmerabile push/with push dimmable driver 220/240V **LED**

CE

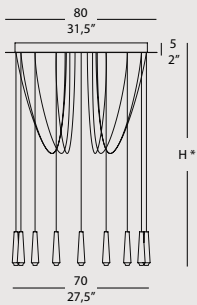
**SANTRAL LA 16 GLASS_S****Cavo/cable standard cm 200/78,8"**

16 x 3,2W 5680 Lm 3000K Cri>80 220/240V

16 x 3,2W 5360 Lm 2700K Cri>80 220/240V **LED****SANTRAL LA 16 GLASS_S DIM PD**

16 x 3,2W 5680 Lm 3000K Cri>80 220/240V

16 x 3,2W 5360 Lm 2700K Cri>80 220/240V

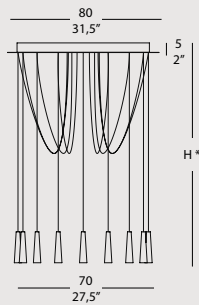
con driver dimmerabile push/with push dimmable driver 220/240V **LED****SANTRAL LA 16_S DIM PD****Cavo/cable standard cm 200/78,8"**

16 x 3,2W 5680 Lm 3000K Cri>80 220/240V

16 x 3,2W 5360 Lm 2700K Cri>80 220/240V **LED****SANTRAL LA 16_S DIM PD**

16 x 3,2W 5680 Lm 3000K Cri>80 220/240V

16 x 3,2W 5360 Lm 2700K Cri>80 220/240V

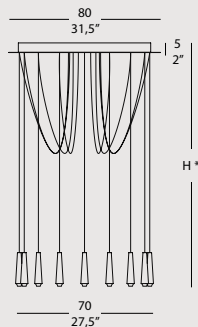
con driver dimmerabile push/with push dimmable driver 220/240V **LED****SANTRAL LA 16 GLASS_L****Cavo/cable standard cm 280/110,2"**

16 x 3,2W 5680 Lm 3000K Cri>80 220/240V

16 x 3,2W 5360 Lm 2700K Cri>80 220/240V **LED****SANTRAL LA 16 GLASS_L DIM PD**

16 x 3,2W 5680 Lm 3000K Cri>80 220/240V

16 x 3,2W 5360 Lm 2700K Cri>80 220/240V

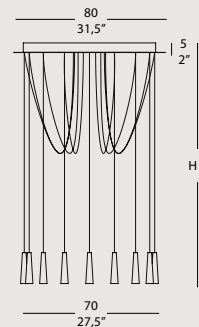
con driver dimmerabile push/with push dimmable driver 220/240V **LED****SANTRAL LA 16_L****Cavo/cable standard cm 280/110,2"**

16 x 3,2W 5680 Lm 3000K Cri>80 220/240V

16 x 3,2W 5360 Lm 2700K Cri>80 220/240V **LED****SANTRAL LA 16_L DIM PD**

16 x 3,2W 5680 Lm 3000K Cri>80 220/240V

16 x 3,2W 5360 Lm 2700K Cri>80 220/240V

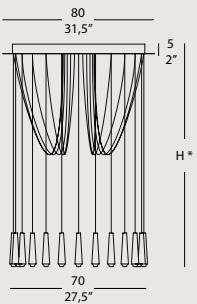
con driver dimmerabile push/with push dimmable driver 220/240V **LED****SANTRAL LA 24 GLASS_S****Cavo/cable standard cm 200/78,8"**

24 x 3,2W 8520 Lm 3000K Cri>80 220/240V

24 x 3,2W 8040 Lm 2700K Cri>80 220/240V **LED****SANTRAL LA 24 GLASS_S DIM PD**

24 x 3,2W 8520 Lm 3000K Cri>80 220/240V

24 x 3,2W 8040 Lm 2700K Cri>80 220/240V

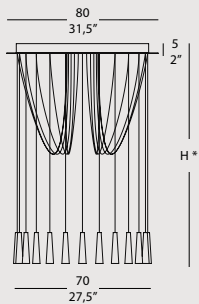
con driver dimmerabile push/with push dimmable driver 220/240V **LED****SANTRAL LA 24_S****Cavo/cable standard cm 200/78,8"**

24 x 3,2W 8520 Lm 3000K Cri>80 220/240V

24 x 3,2W 8040 Lm 2700K Cri>80 220/240V **LED****SANTRAL LA 24_S DIM PD**

24 x 3,2W 8520 Lm 3000K Cri>80 220/240V

24 x 3,2W 8040 Lm 2700K Cri>80 220/240V

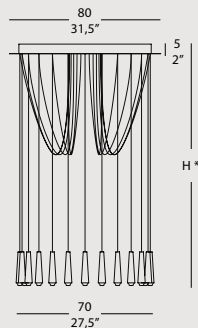
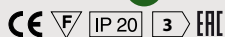
con driver dimmerabile push/with push dimmable driver 220/240V **LED****SANTRAL LA 24 GLASS_L****Cavo/cable standard cm 280/110,2"**

24 x 3,2W 8520 Lm 3000K Cri>80 220/240V

24 x 3,2W 8040 Lm 2700K Cri>80 220/240V **LED****SANTRAL LA 24 GLASS_L DIM PD**

24 x 3,2W 8520 Lm 3000K Cri>80 220/240V

24 x 3,2W 8040 Lm 2700K Cri>80 220/240V

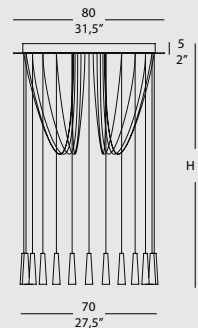
con driver dimmerabile push/with push dimmable driver 220/240V **LED****SANTRAL LA 24_L****Cavo/cable standard cm 280/110,2"**

24 x 3,2W 8520 Lm 3000K Cri>80 220/240V

24 x 3,2W 8040 Lm 2700K Cri>80 220/240V **LED****SANTRAL LA 24_L DIM PD**

24 x 3,2W 8520 Lm 3000K Cri>80 220/240V

24 x 3,2W 8040 Lm 2700K Cri>80 220/240V

con driver dimmerabile push/with push dimmable driver 220/240V **LED**

H*
Altezza variabile/Variable height
Höhenverstellbar/Hauteur variable
Altura variable/меняющаяся высота

**SU RICHIESTA È POSSIBILE AVERE ANCHE DRIVER DIMMERABILE 1/10V O DALI
1/10V AND DALI DIMMABLE DRIVER CAN BE SUPPLIED BY REQUEST**

Rilettura in chiave destrutturata dell'estetica classica dei lampadari a sospensione. Mikado è un intreccio di linee e piani che producono un fluttuante movimento nello spazio generando figure geometriche semplici o complesse.

Le varie versioni a sospensione, lineari o circolari, permettono diversi gradi di personalizzazione ed elaborazione della struttura: sobria e minimalista o complessa ed eccentrica grazie alla sovrapposizione di piani ad altezze asimmetriche.

Le sorgenti a LED sono racchiuse in particolari metallici di forma conica, disponibili anche con diffusore in vetro soffiato satinato che impreziosisce ulteriormente la collezione.

A deconstructive reinterpretation of the classical aesthetics of pendant chandeliers. Mikado is a mixture of lines and planes that produce a fluctuating movement in space creating simple or complex geometric figures.

The various linear or circular pendant versions allow different degrees of customization and elaboration of the frame: simple and minimalist or complex and eccentric thanks to the overlapping planes at asymmetric heights. The LED sources are enclosed inside of conical metallic elements, available also with satin blown glass diffuser, further enriching the collection.

Eine unstrukturierte Neuinterpretation der klassischen Ästhetik von Hängelampen. Mikado ist ein Geflecht aus Linien und Ebenen das schwankende Bewegungen im Raum produziert, indem es einfache und komplexe Geometrie-Figuren erzeugt. Die verschiedenen Ausführungen der Abhängungen, linear oder kreisförmig, ermöglichen diverse Möglichkeiten der Personalisierung und Ausarbeitung der Struktur:

schlicht und minimalistisch, oder komplex und exzentrisch, dank der Überlappung der Ebenen in asymmetrischen Abständen. Die LED-Lichtquellen sind eingeschlossen in metallische Teile mit konischer Form. Erhältlich auch mit Diffusor aus satiniertem und geblasenen Glas, das die Kollektion nochmals erheblich aufwertet.

Relecture sous un jour déstructuré de l'esthétique classique des lustres à suspension. Mikado est un enchevêtrement de lignes et de plans qui produisent un mouvement fluctuant dans l'espace générant des figures géométriques simples ou complexes.

Les différentes versions à suspension, linéaires ou circulaires, permettent différents degrés de personnalisation et d'élaboration de la structure : sobre et minimaliste ou complexe et excentrique grâce à la superposition de plans à des hauteurs asymétriques.

Les sources à LED sont contenues dans des éléments métalliques de forme conique, également fournis avec un diffuseur en verre soufflé satiné qui enrichit ultérieurement la collection.

Relectura en clave descompuesta de la estética clásica de las lucernas suspendidas, Mikado es un enredo de líneas y planos que producen un movimiento oscilante en el espacio generando figuras geométricas simples y complejas.

Las varias versiones a suspensión, lineales o circulares, permiten varios grados de personalización y elaboración de la estructura: sobria y minimalista o compleja y excéntrica gracias a la sobreposición de planos de alturas asimétricas.

Las fuentes de LED están encerradas en detalles metálicos de forma cónica, disponibles incluso con difusor de vidrio soplado satinado que valoriza ulteriormente la colección.

Новая интерпретация в деструктивном ключе классической эстетики подвесных светильников.

Mikado – это переплетение линий и плоскостей, которые вызывает колеблющееся движение в пространстве, создавая простые и сложные геометрические фигуры.

Разнообразные версии подвесного светильника, как с линейным, так и с круговым расположением, позволяют разную степень персонализации и отделки структуры: строгую и минималистичную или, благодаря асимметричному расположению плоскостей по высоте, сложную и эксцентричную. Источники LED заключены в металлические элементы конической формы, которые также могут быть предложены с рассеивателем из дутого сатинированного стекла, придающего коллекции дополнительную ценность.

Struttura: metallo nero opaco.

Frame: matt black metal.

Struktur: Metall, mattschwarz.

Structure: métal noir mat.

Estruttura: metal negro opaco.

Структура: металл, выполняется в черном матовом цвете.

Diffusore: vetro satinato.

Diffuser: satin glass.

Difusor: Satiniertes Glas.

Diffuseur: verre satiné.

Difusor: vidrio satinado.

Рассеиватель: Сатинированное стекло.

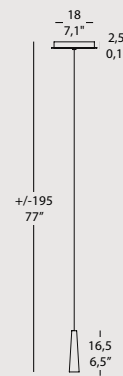
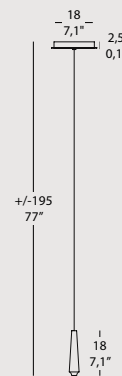
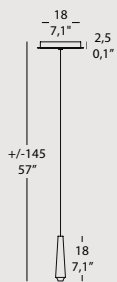

MIKADO SO 1 GLASS_S

1 x 3,2W 355 Lm 3000K Cri>80 220/240V

1 x 3,2W 335 Lm 2700K Cri>80 220/240V **LED**

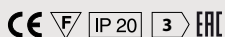

MIKADO SO 1_S

1 x 3,2W 355 Lm 3000K Cri>80 220/240V

1 x 3,2W 335 Lm 2700K Cri>80 220/240V **LED**

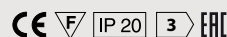

MIKADO SO 1 GLASS_L

1 x 3,2W 355 Lm 3000K Cri>80 220/240V

1 x 3,2W 335 Lm 2700K Cri>80 220/240V **LED**

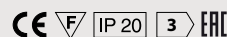

MIKADO SO 1_L

1 x 3,2W 355 Lm 3000K Cri>80 220/240V

1 x 3,2W 335 Lm 2700K Cri>80 220/240V **LED**

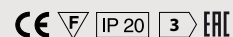

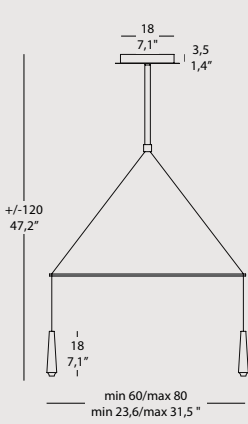

MIKADO S2L GLASS_S

2 x 3,2W 710 Lm 3000K Cri>80 220/240V
2 x 3,2W 670 Lm 2700K Cri>80 220/240V **LED**

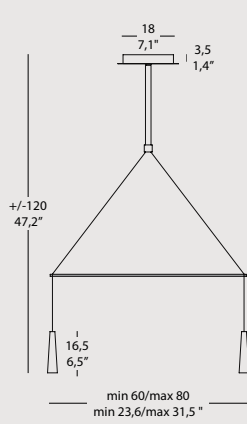
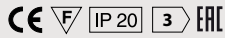

MIKADO S2L_S

2 x 3,2W 710 Lm 3000K Cri>80 220/240V
2 x 3,2W 670 Lm 2700K Cri>80 220/240V **LED**

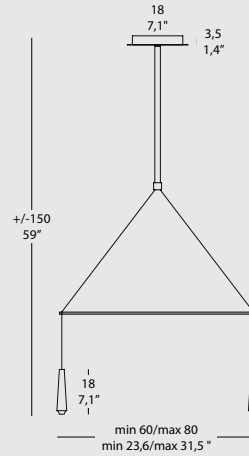
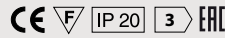

MIKADO S2L GLASS_L

2 x 3,2W 710 Lm 3000K Cri>80 220/240V
2 x 3,2W 670 Lm 2700K Cri>80 220/240V **LED**

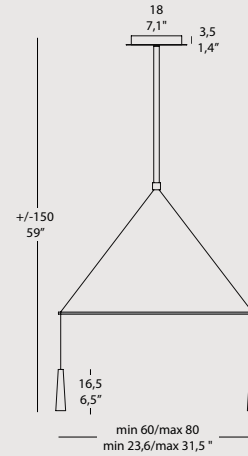
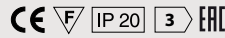

MIKADO S2L_L

2 x 3,2W 710 Lm 3000K Cri>80 220/240V
2 x 3,2W 670 Lm 2700K Cri>80 220/240V **LED**

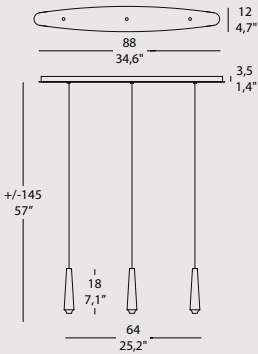
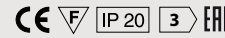

MIKADO S3L GLASS_S

3 x 3,2W 1065 Lm 3000K Cri>80 220/240V
3 x 3,2W 1005 Lm 2700K Cri>80 220/240V **LED**

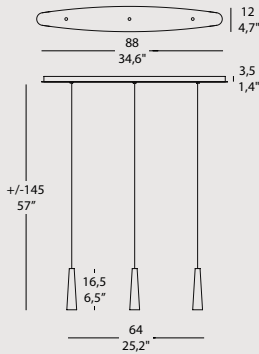
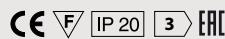

MIKADO S3L_S

3 x 3,2W 1065 Lm 3000K Cri>80 220/240V
3 x 3,2W 1005 Lm 2700K Cri>80 220/240V **LED**

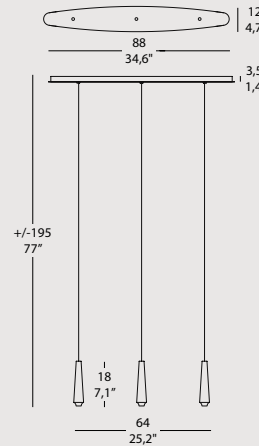

MIKADO S3L GLASS_L

3 x 3,2W 1065 Lm 3000K Cri>80 220/240V
3 x 3,2W 1005 Lm 2700K Cri>80 220/240V **LED**

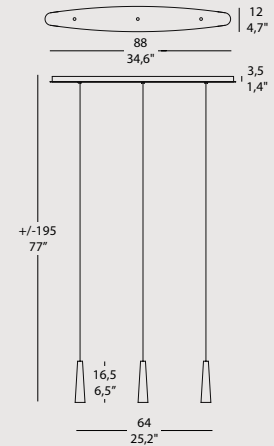

MIKADO S3L_L

3 x 3,2W 1065 Lm 3000K Cri>80 220/240V
3 x 3,2W 1005 Lm 2700K Cri>80 220/240V **LED**

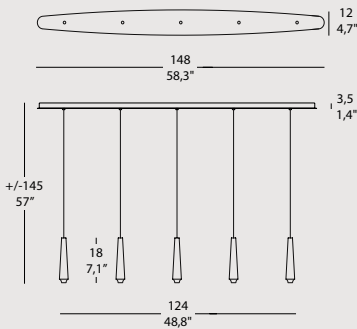

MIKADO S5L GLASS_S

5 x 3,2W 1775 Lm 3000K Cri>80 220/240V
5 x 3,2W 1675 Lm 2700K Cri>80 220/240V **LED**

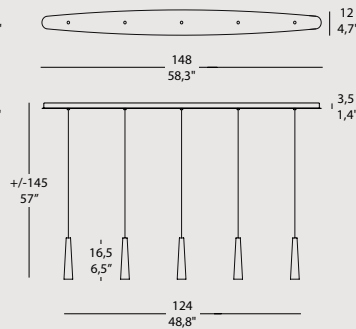

MIKADO S5L_S

5 x 3,2W 1775 Lm 3000K Cri>80 220/240V
5 x 3,2W 1675 Lm 2700K Cri>80 220/240V **LED**

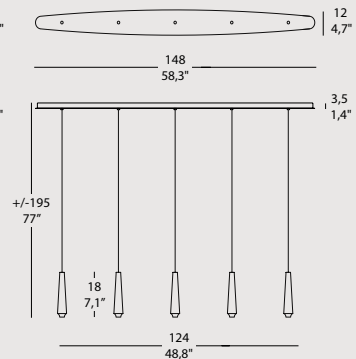
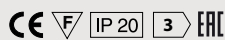

MIKADO S5L GLASS_L

5 x 3,2W 1775 Lm 3000K Cri>80 220/240V
5 x 3,2W 1675 Lm 2700K Cri>80 220/240V **LED**

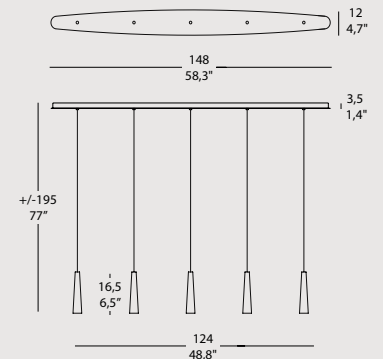
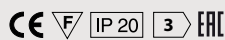

MIKADO S5L_L

5 x 3,2W 1775 Lm 3000K Cri>80 220/240V
5 x 3,2W 1675 Lm 2700K Cri>80 220/240V **LED**



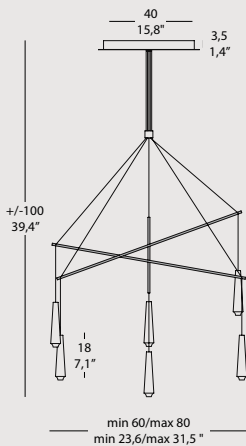

MIKADO LA 6 GLASS_S

6 x 3,2W 2130 Lm 3000K Cri>80 220/240V

6 x 3,2W 2010 Lm 2700K Cri>80 220/240V **LED**

MIKADO LA 6 GLASS_S DIM PD

6 x 3,2W 2130 Lm 3000K Cri>80 220/240V

6 x 3,2W 2010 Lm 2700K Cri>80 220/240V

con driver dimmerabile push/with push dimmable driver 220/240V **LED**

CE **F** IP 20 **3** EAC

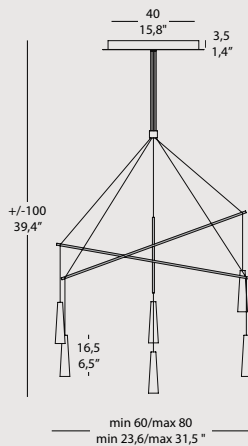

MIKADO LA 6_S

6 x 3,2W 2130 Lm 3000K Cri>80 220/240V

6 x 3,2W 2010 Lm 2700K Cri>80 220/240V **LED**

MIKADO LA 6_S DIM PD

6 x 3,2W 2130 Lm 3000K Cri>80 220/240V

6 x 3,2W 2010 Lm 2700K Cri>80 220/240V

con driver dimmerabile push/with push dimmable driver 220/240V **LED**

CE **F** IP 20 **3** EAC

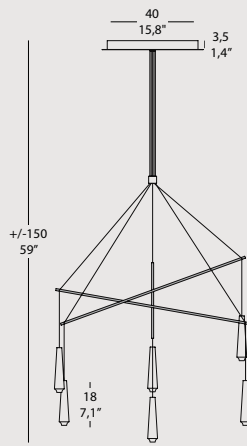

MIKADO LA 6 GLASS_L

6 x 3,2W 2130 Lm 3000K Cri>80 220/240V

6 x 3,2W 2010 Lm 2700K Cri>80 220/240V **LED**

MIKADO LA 6 GLASS_L DIM PD

6 x 3,2W 2130 Lm 3000K Cri>80 220/240V

6 x 3,2W 2010 Lm 2700K Cri>80 220/240V

con driver dimmerabile push/with push dimmable driver 220/240V **LED**

CE **F** IP 20 **3** EAC

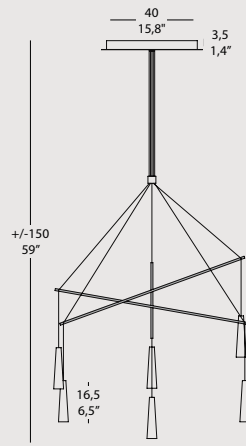

MIKADO LA 6_L

6 x 3,2W 2130 Lm 3000K Cri>80 220/240V

6 x 3,2W 2010 Lm 2700K Cri>80 220/240V **LED**

MIKADO LA 6_L DIM PD

6 x 3,2W 2130 Lm 3000K Cri>80 220/240V

6 x 3,2W 2010 Lm 2700K Cri>80 220/240V

con driver dimmerabile push/with push dimmable driver 220/240V **LED**

CE **F** IP 20 **3** EAC

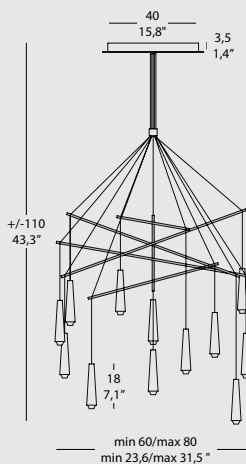

MIKADO LA 12 GLASS_S

12 x 3,2W 4260 Lm 3000K Cri>80 220/240V

12 x 3,2W 4020 Lm 2700K Cri>80 220/240V **LED**

MIKADO LA 12 GLASS_S DIM PD

12 x 3,2W 4260 Lm 3000K Cri>80 220/240V

12 x 3,2W 4020 Lm 2700K Cri>80 220/240V

con driver dimmerabile push/with push dimmable driver 220/240V **LED**

CE **F** IP 20 **3** EAC

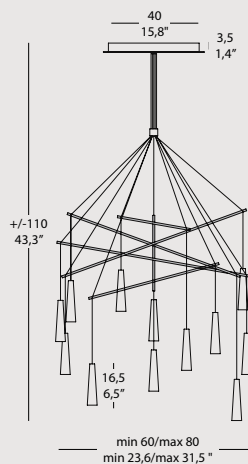

MIKADO LA 12_S

12 x 3,2W 4260 Lm 3000K Cri>80 220/240V

12 x 3,2W 4020 Lm 2700K Cri>80 220/240V **LED**

MIKADO LA 12_S DIM PD

12 x 3,2W 4260 Lm 3000K Cri>80 220/240V

12 x 3,2W 4020 Lm 2700K Cri>80 220/240V

con driver dimmerabile push/with push dimmable driver 220/240V **LED**

CE **F** IP 20 **3** EAC

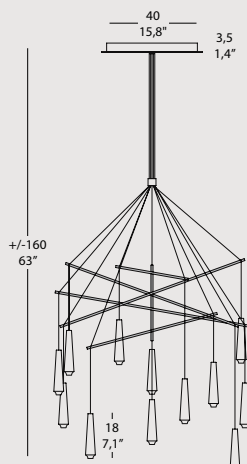

MIKADO LA 12 GLASS_L

12 x 3,2W 4260 Lm 3000K Cri>80 220/240V

12 x 3,2W 4020 Lm 2700K Cri>80 220/240V **LED**

MIKADO LA 12 GLASS_L DIM PD

12 x 3,2W 4260 Lm 3000K Cri>80 220/240V

12 x 3,2W 4020 Lm 2700K Cri>80 220/240V

con driver dimmerabile push/with push dimmable driver 220/240V **LED**

CE **F** IP 20 **3** EAC

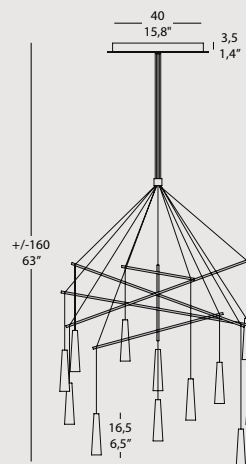

MIKADO LA 12_L

12 x 3,2W 4260 Lm 3000K Cri>80 220/240V

12 x 3,2W 4020 Lm 2700K Cri>80 220/240V **LED**

MIKADO LA 12_L DIM PD

12 x 3,2W 4260 Lm 3000K Cri>80 220/240V

12 x 3,2W 4020 Lm 2700K Cri>80 220/240V

con driver dimmerabile push/with push dimmable driver 220/240V **LED**

CE **F** IP 20 **3** EAC

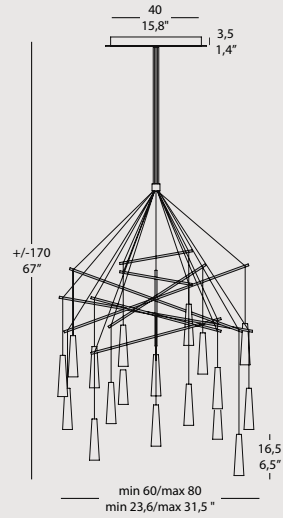
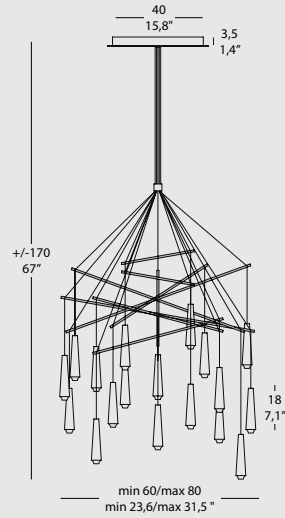
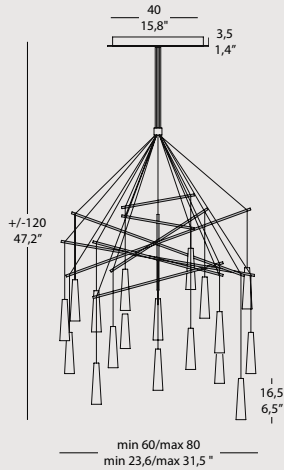
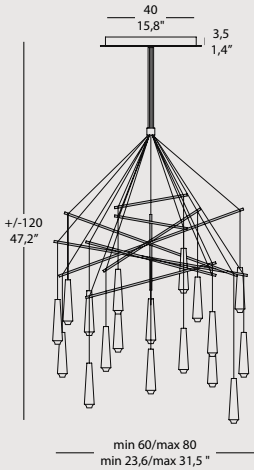

MIKADO LA 18 GLASS_S

18 x 3,2W 6390 Lm 3000K Cri>80 220/240V
18 x 3,2W 6030 Lm 2700K Cri>80 220/240V **LED**

MIKADO LA 18 GLASS_S DIM PD

18 x 3,2W 6390 Lm 3000K Cri>80 220/240V
18 x 3,2W 6030 Lm 2700K Cri>80 220/240V
con driver dimmerabile push/with push dimmable driver 220/240V **LED**



MIKADO LA 18_S

18 x 3,2W 6390 Lm 3000K Cri>80 220/240V
18 x 3,2W 6030 Lm 2700K Cri>80 220/240V **LED**

MIKADO LA 18_S DIM PD

18 x 3,2W 6390 Lm 3000K Cri>80 220/240V
18 x 3,2W 6030 Lm 2700K Cri>80 220/240V
con driver dimmerabile push/with push dimmable driver 220/240V **LED**

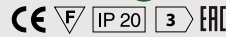

MIKADO LA 18 GLASS_L

18 x 3,2W 6390 Lm 3000K Cri>80 220/240V
18 x 3,2W 6030 Lm 2700K Cri>80 220/240V **LED**

MIKADO LA 18 GLASS_L DIM PD

18 x 3,2W 6390 Lm 3000K Cri>80 220/240V
18 x 3,2W 6030 Lm 2700K Cri>80 220/240V
con driver dimmerabile push/with push dimmable driver 220/240V **LED**



MIKADO LA 18_L

18 x 3,2W 6390 Lm 3000K Cri>80 220/240V
18 x 3,2W 6030 Lm 2700K Cri>80 220/240V **LED**

MIKADO LA 18_L DIM PD

18 x 3,2W 6390 Lm 3000K Cri>80 220/240V
18 x 3,2W 6030 Lm 2700K Cri>80 220/240V
con driver dimmerabile push/with push dimmable driver 220/240V **LED**



**SU RICHIESTA È POSSIBILE AVERE ANCHE DRIVER DIMMERABILE 1/10V
1/10V DIMMABLE DRIVER CAN BE SUPPLIED BY REQUEST**

**BARRA/BAR 50
NERO/BLACK**

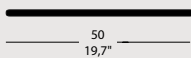

**BARRA/BAR 75
NERO/BLACK**

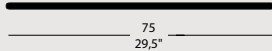

DIFFUSORE/DIFFUSER

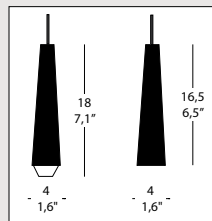

EviStyle[®]





TROTTOLA

design  Stefano Mandruzzato

Un girotondo di luce
che evoca un gioco
custodito nella memoria

A circle of light that evokes
a toy preserved
in the memory



Trottola_SO Medium





Trottola_SO Big



Trottola_SO 7 esempio di composizione _example of composition





TROTTOLA

technical data

Ispirata per nome e forma al secolare gioco per bambini, Trottola è una collezione di sospensioni in vetro soffiato composta da tre elementi dalla forte personalità.

Ironica, evocativa, giocosa, Trottola ci porta alla riscoperta della nostra infanzia. Disponibile in diverse soluzioni a sospensione, si presta sia per l'utilizzo domestico che per contract. La componente modulare permette innumerevoli combinazioni di customizzazione per soddisfare ogni esigenza del cliente. L'intera collezione utilizza sorgenti led dimmerabili.

Сon nom et sa forme s'inspirent du jeu enfantin séculaire: Trottola est une collection de suspensions en verre soufflé constituée par trois éléments de caractère.

Ironique, évocatrice, gaie, Trottola nous mène à la découverte de notre enfance. Les différents modèles à suspension sont parfaits pour l'usage domestique et les collectivités. La composante modulaire permet d'innombrables combinaisons de personnalisation pour satisfaire toute exigence du client. Toute la collection utilise des sources led dimmables.

Inspired by the age-old game for children both in the name and shape, Trottola is a collection of three different blown glass suspensions with a strong personality.

Ironic, evocative, playful, Trottola brings us to the rediscovery of our childhood. Available in different suspension solutions, it is suitable both for private use and contract. The modular component allows countless combinations of customization to meet all customers' needs. The entire collection uses dimmable LED sources.

Trottola, cuyo nombre y forma se inspiran al antiguo juguete de la peonza, es una colección de colgantes de vidrio soplado que se compone por tres elementos con una personalidad fuerte.

Irónica, evocadora, jocosa, Trottola nos lleva a redescubrir nuestra infancia. Es disponible en diferentes opciones de colgante y se presta tanto al uso doméstico como al contract. El componente modular permite múltiples combinaciones para satisfacer la necesidad de customización de cada cliente. Toda la colección emplea fuentes led regulables.

Trottola hat sich von Namen und Form dieses Spiels inspirieren lassen. Trottola ist eine aus geblasenem Glas angefertigte Pendelleuchtenfamilie, die aus drei Elementen mit einer hohen Individualität besteht.

Ironisch, Erinnerungen wachrufend, verspielt...Trottola bringt uns in die eigene Kindheit zurück. Sie ist in verschiedenen Ausführungen erhältlich, für das Haus wie für Objekte geeignet. Der modulare Bestandteil ermöglicht zahlreiche Kombinationen, um jeder Anforderung des Kunden gerecht zu werden. Die ganze Kollektion nutzt dimmbare Led-Lichtquellen.

Образ светильника и его название (Trottola - волчок, в переводе с итальянского), навеян старой детской игрушкой. Trottola - коллекция из трех подвесных светильников разных форм, выполненных из выдувного стекла. Ироничный, игривый, навивающий воспоминания, Trottola возвращает нас в детство. Доступный в разных решениях, светильник подойдёт как для частного интерьера, так и для общественного. Модульность системы позволяет создавать бесчисленное количество комбинаций и кастомизаций, чтобы удовлетворить все потребности клиента. Вся коллекция оснащена диммируемыми светодиодами.

Struttura: rosone bianco - altre parti in metallo nelle colorazioni: nero opaco, oro opaco.

Diffusore: vetro soffiato nelle colorazioni: trasparente, bianco seta, ambra metallizzato, fumè metallizzato.

Frame: white canopy - other metal parts in the colors: matt black, matt gold.

Diffuser: blown glass in the following colors: transparent, white silk, metalized amber, metalized smoke-grey.

Struktur: Baldachin Weiß - die anderen Teile aus Metall in den Farben: Mattschwarz, Mattgold.

Diffusor: geblasenes Glas in den Farben: Transparent, Seidenweiß, Metallic-bernstein, Metallic-fumè.

Structure: rosette blanche - autres parties en métal dans les teintes : noir mat, or mat.

Diffuseur: verre soufflé dans les teintes : transparent, blanc soie, ambre métallisé, fumè métallisé.

Estruttura: rosetón blanco; otras partes de metal en los siguientes colores: negro mate, oro mate.

Diffusor: vidrio soplado en los colores: transparente, blanco seda, ámbar metalizado, gris ahumado metalizado.

Структура: белый розон, остальные металлические части - матовый чёрный либо матовое золото.

Рассеиватель: Выдувное стекло в цветах: прозрачный, белый шёлк, металлизированный янтарь, металлизированный дымчатый.



CT: Trasparente/
Transparent



SE: Bianco seta/
White silk

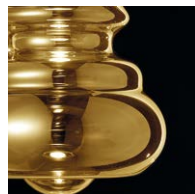

AM: Ambra
Metallizzato/
Metalized Amber



FU: Fumè
metallizzato/Metalized
smoke-grey

SOSPENSIONI (CAVO STANDARD CM 250)/PENDANT LAMPS (STANDARD CABLE CM 250)

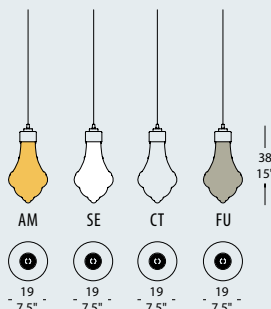

TROTTOLA SO SMALL

10W 1.400 Lm 2700K Cri>80 300 mA LED

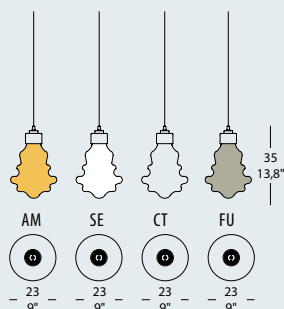
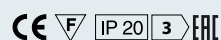

TROTTOLA SO MEDIUM

10W 1.400 Lm 2700K Cri>80 300 mA LED

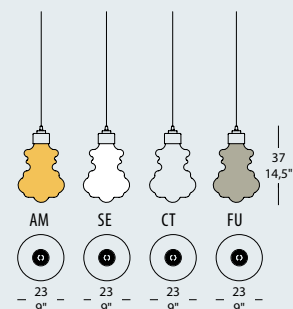
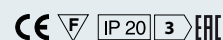

TROTTOLA SO BIG

10W 1.400 Lm 2700K Cri>80 300 mA LED

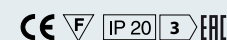

ROSONI/CANOPIES

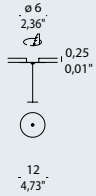

TROTTOLA IN-1

ROSONE A INCASSO A 1 LUCE CON DRIVER 220/240Vac 50-60 Hz
1-LIGHT RECESSED CANOPY WITH DRIVER 220/240Vac 50-60 Hz

TROTTOLA IN-1 DIM PD

ROSONE A INCASSO A 1 LUCE CON DRIVER DIMMERABILE PUSH 220/240Vac 50-60 HZ
1-LIGHT RECESSED CANOPY WITH PUSH DIMMABLE DRIVER 220/240Vac 50-60 HZ

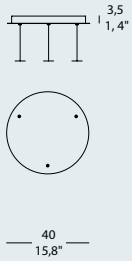

TROTTOLA R03

ROSONE A 3 LUCI CON DRIVER 220/240Vac 50-60 Hz
3-LIGHT CANOPY WITH DRIVER 220/240Vac 50-60 Hz

TROTTOLA R03 DIM PD

ROSONE A 3 LUCI CON DRIVER DIMMERABILE PUSH 220/240Vac 50-60 HZ
3-LIGHT CANOPY WITH PUSH DIMMABLE DRIVER 220/240Vac 50-60 HZ

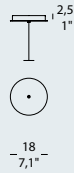

TROTTOLA R01

ROSONE A 1 LUCE CON DRIVER 220/240Vac 50-60 Hz
1-LIGHT CANOPY WITH DRIVER 220/240Vac 50-60 Hz

TROTTOLA R01 DIM PD

ROSONE A 1 LUCE CON DRIVER DIMMERABILE PUSH 220/240Vac 50-60 HZ
1-LIGHT CANOPY WITH PUSH DIMMABLE DRIVER 220/240Vac 50-60 HZ

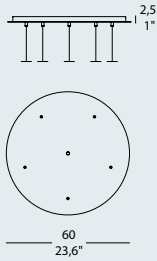

TROTTOLA R05

ROSONE A 5 LUCI CON DRIVER 220/240Vac 50-60 Hz
5-LIGHT CANOPY WITH DRIVER 220/240Vac 50-60 Hz

TROTTOLA R05 DIM PD

ROSONE A 5 LUCI CON DRIVER DIMMERABILE PUSH 220/240Vac 50-60 HZ
5-LIGHT CANOPY WITH PUSH DIMMABLE DRIVER 220/240Vac 50-60 HZ

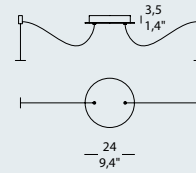

TROTTOLA R02

ROSONE A 2 LUCI CON DRIVER 220/240Vac 50-60 Hz
2-LIGHT CANOPY WITH DRIVER 220/240Vac 50-60 Hz

TROTTOLA R02 DIM PD

ROSONE A 2 LUCI CON DRIVER DIMMERABILE PUSH 220/240Vac 50-60 HZ
2-LIGHT CANOPY WITH PUSH DIMMABLE DRIVER 220/240Vac 50-60 HZ

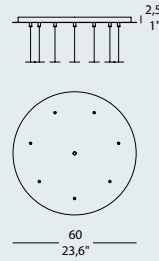

TROTTOLA R07

ROSONE A 7 LUCI CON DRIVER 220/240Vac 50-60 Hz
7-LIGHT CANOPY WITH DRIVER 220/240Vac 50-60 Hz

TROTTOLA R07 DIM PD

ROSONE A 7 LUCI CON DRIVER DIMMERABILE PUSH 220/240Vac 50-60 HZ
7-LIGHT CANOPY WITH PUSH DIMMABLE DRIVER 220/240Vac 50-60 HZ



**SU RICHIESTA È POSSIBILE AVERE ANCHE DRIVER DIMMERABILE 1/10V
1/10V DIMMABLE DRIVER CAN BE SUPPLIED BY REQUEST**

ESEMPI DI COMPOSIZIONE/ EXAMPLES OF COMPOSITION

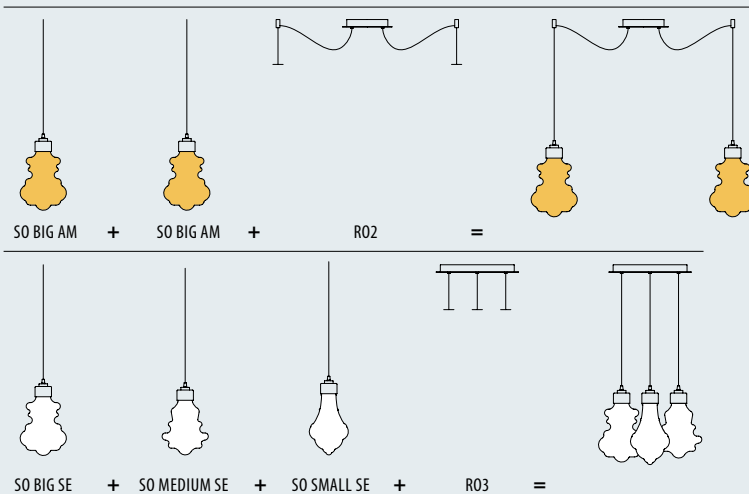

LEGENDA



Tutte le lampade sono costruite secondo le norme europee EN 60598-1 e con materiali approvati da vari istituti di sicurezza.
All the lamps are made according to European standards EN 60598-1 and of materials approved by various safety institutes.



Apparecchio predisposto per il montaggio su superfici infiammabili.
Fixture ready for mounting on inflammable surfaces.



Apparecchio in classe II - Apparecchio nel quale la protezione contro la scossa elettrica non si basa unicamente sull'isolamento fondamentale, ma anche sulle misure supplementari di sicurezza costituite dal doppio isolamento o dall'isolamento rinforzato. Queste misure non comportano dispositivi per la messa a terra e non dipendono dalle condizioni d'installazione.

Class II appliance - appliance in which protection against electric shock is not only based on basic insulation, but also on additional safety measures, i.e. double insulation or reinforced insulation. These measures do not involve earthing devices and do not depend on the installation conditions.



Risparmio di energia.
Energy saving.



Grado di protezione - Stabilisce un sistema per la classificazione degli apparecchi elettrici in base al grado di protezione fornito dagli involucri degli stessi.







I simboli utilizzati per indicare questo grado di protezione sono costituiti dalle lettere "IP" seguite da due cifre caratteristiche:

- la prima cifra indica la protezione contro la penetrazione dei corpi solidi e della polvere;
- la seconda cifra indica la protezione contro la penetrazione dei liquidi.

Protection level - This establishes a classification system for electric appliances based on the protection level supplied by their casing. The symbols used to indicate the level of protection are the two letters, "IP" followed by two figures.

- The first figure indicates the protection against penetration by solid bodies and dust;
- The second figure indicates the protection against penetration by liquids.

Gradi di protezione IP - Protection degrees (IP)

1ª cifra protezione alla penetrazione di corpi solidi. 1st figure: protection against penetration by solid bodies.		2ª cifra protezione contro la penetrazione d'acqua. 2nd figure: protection against penetration by water.	
0	Non Protetto. No protection.	0	Non Protetto. No protection.
1	Protetto da corpi solidi superiori a 50 mm. Protected against solid matters (over 50 mm.).	1	Protetto contro lo stilloccidio. Protected proof fixture. 
2	Protetto da corpi solidi superiori a 12 mm. Protected against solid matters (over 12 mm.).	2	Protetto da cadute d'acqua, inclinazione di 15. Protected against water falling at 15 angle.
3	Protetto da corpi solidi superiori a 2,5 mm. Protected against solid matters (over 2,5 mm.).	3	Protetto contro la pioggia. Rain proof fixture. 
4	Protetto da corpi solidi superiori a 1 mm. Protected against solid matters (over 1 mm.).	4	Protetto contro gli spruzzi. Splash proof fixture. 
5	Protetto contro la polvere. Dust proof. 	5	Protetto contro getti d'acqua. Water jet proof. 
6	Totalmente protetto contro la polvere. Fully dust. 	6	Protetto contro le ondate. Wave proof.



Articoli con moduli LED: consumo ridotto, lunga durata.
Articles with LED modules: low consumption, long life.



LED con alimentazione diretta a tensione di rete (non necessita di driver). Dimmerabile con varialuce a taglio di fase.
LED with direct power supply to the AC line voltage (driver not required). Dimmable with phase cut dimming.

ETICHETTE ENERGETICHE DI PRODOTTO - PRODUCT ENERGY LABELS
ENERGIE-EFFIZIENZETIKETTEN DES PRODUKT - ÉTIQUETTE D'ENERGIE DU PRODUIT
ETIQUETAS ENERGÉTICAS DE PRODUCTO – ЭНЕРГЕТИЧЕСКАЯ МАРКИРОВКА ПРОДУКЦИИ.

Indicano la classe di efficienza energetica delle sorgenti luminose compatibili con l'apparecchio d'illuminazione.

Indicate the class of Energy-efficiency of light sources compatible with the lighting device.

Zeigen die Klasse der Energie-Effizienz der mit dem Beleuchtungsgerät kompatiblen Lichtquellen an.

Montrent la classe du rendement d'énergie des sources lumineuses compatibles avec l'appareil d'illumination.

Indican la clase de eficiencia energetica de los surgentes luminosos compatibles con el aparato de iluminación.

указывают класс энергетической эффективности источников света совместимых с осветительным устройством.

1 = Questo dispositivo è compatibile con lampadine di classi energetiche:
 Diese Leuchte ist geeignet für Leuchtmittel der Energieklassen:
 This luminaire is compatible with bulbs of the energy classes:
 Ce luminaire est compatible avec des ampoules des classes énergétiques:
 Esta luminaria es compatible con bombillas de las clases energéticas:
 Этот прибор совместим с лампочками следующих классов энергетической эффективности:

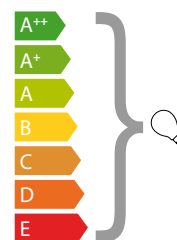

2 = Questo dispositivo è compatibile con lampadine di classi energetiche:
 Diese Leuchte ist geeignet für Leuchtmittel der Energieklassen:
 This luminaire is compatible with bulbs of the energy classes:
 Ce luminaire est compatible avec des ampoules des classes énergétiques:
 Esta luminaria es compatible con bombillas de las clases energéticas:
 Этот прибор совместим с лампочками следующих классов энергетической эффективности:

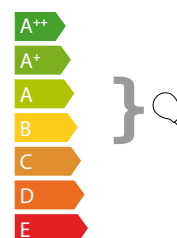

3 = Questo dispositivo è munito di lampade a LED integrate.
 Le lampade di questo dispositivo non sono sostituibili.
 This luminaire contains built-in LED lamps.
 The lamps cannot be changed in the luminaire.
 Diese Leuchte enthält eingebaute LED-Lampen.
 Die Lampen können in der Leuchte nicht ausgetauscht werden.
 Ce luminaire comporte des lampes à LED intéégrées.
 Les lampes de ce luminaire ne peuvent pas être changées.
 Esta luminaria lleva lámparas LED incorporadas.
 Las lámparas de esta luminaria no son recambiables.
 Этот прибор снабжен встроенным LED источником.
 Лампочки этого прибора не подлежат замене.



Certificazione di conformità valida per l'unione doganale EurAsEC.

Certification for Eurasian Customs Union.

Zertifizierung nach der europäischen Norm für die Eurasische Wirtschaftsgemeinschaft.

Certificat de conformité pour la Union douanière Eurasienne.

Certificado de conformidad con validez para la Unión Euroasiática.

сертификация соответствия действительна для таможенного союза ЕврАзЭС



Associato/Associate



Ente Aderente
Al Consorzio Veneto Per I Sistemi
Dell'illuminazione

Distributor for
U.S.A.

MEDIALIGHT
— Lighting+Design —

1971 NE 148 ST.
NORTH MIAMI
FL 33141
t. 305.919.0286 f. 305.394.8739

www.medialightusa.com
info@medialightusa.com

MOROSINI

t. +39 041 5952772
f. +39 041 5956175
info@luciitaliane.com
www.morosinisrl.com

Brand of **Luci Italiane** srl
via delle Industrie, 70
30020 Marcon (VE) - Italy

